

PETROL ENGINE

034 - GB - 11/88

Ref. ML RE 01

XU9 J4

Overhaul

TO BE FILED IN THE UNIT OVERHAUL BINDER



**AUTOMOBILES
PEUGEOT**

direction des pièces et services

CONTENTS

	Pages
Foreword	3
IDENTIFICATION - DATA	
- Cylinder head/Cylinder head gasket	4 - 5
- Valves/springs/Camshafts/Camshaft gears	6 - 7
- Valve guides	8 - 9
- Valve seats	10 - 11
- Pistons/Liners	12 - 13
- Crankshaft/bearings	14 - 15
DISMANTLING - RE-ASSEMBLY	
- Tools	16 - 17
- Dismantling	18 - 27
- Re-assembly	
. Cylinder head	28 - 29
. Liner protrusion	30 - 31
. Piston/Connecting rod/Liner assembly	32 - 33
. Crankshaft, bearings	34 - 37
. Oil pump/Sump	36 - 39
. Cylinder head	38 - 41
. Coolant pump/Timing gear	40 - 43
. Engine fittings	44 - 45
- Principal tightening torques	46

CYLINDER HEAD

- Nominal height :
 $h = 132 \text{ mm} \pm 0,15$
- Maximum permissible bow :
 0,05 mm
- Maximum permissible gasket face machining :
 - 0,2 mm

Cylinder heads machined undersize on exchange engines are stamped R at (a).

After re-assembly, the camshafts must turn freely by hand

NOTE

Two non-return valves (set at 0,4 bars, 6 lbf/in²) located at (b) and (c) maintain a residual oil pressure in the hydraulic tappet supply lines.

In case of repair, refit the plugs with threads coated with LOCTITE and tighten to 15 Nm (11 lbf ft).

CYLINDER HEAD GASKET

Thickness :

- 1,45 mm for original height head
- 1,65 mm for machined exchange head

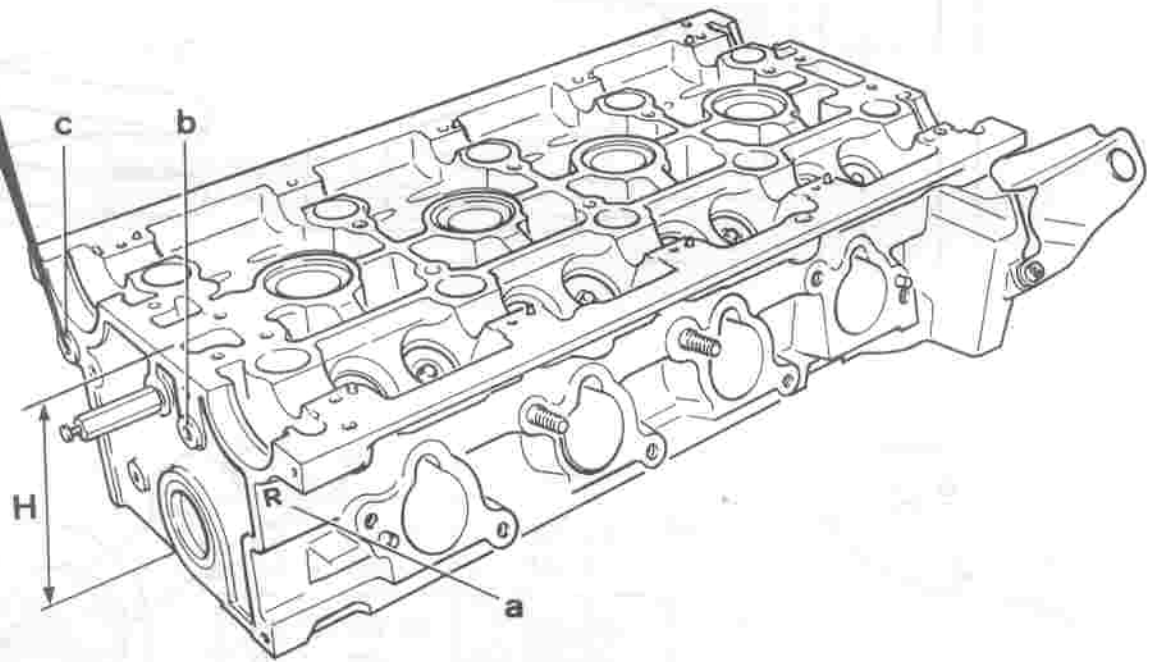
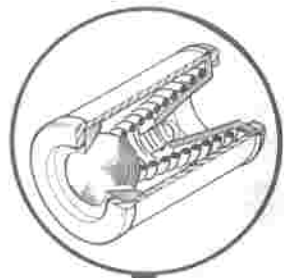

9-5-88 C72

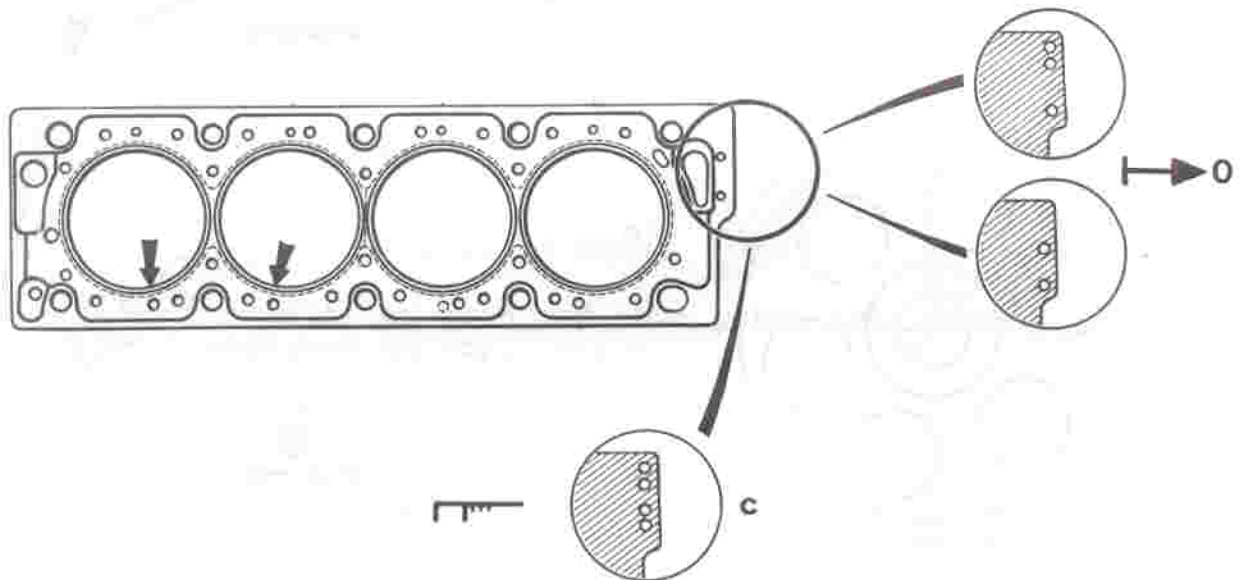

XU9J4

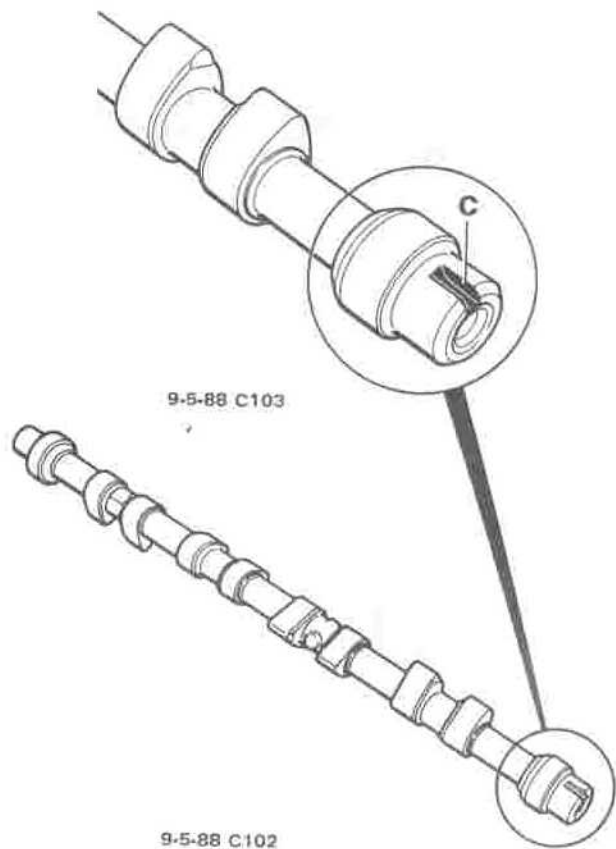
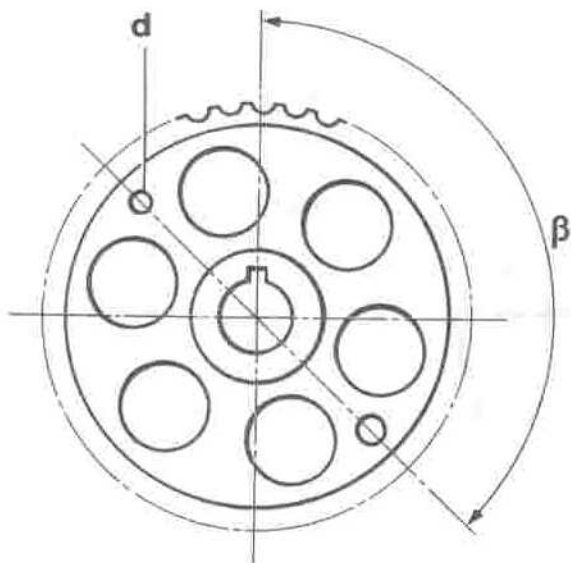
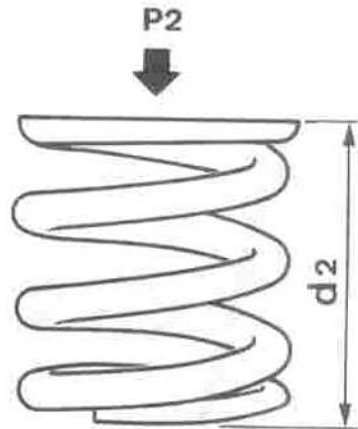
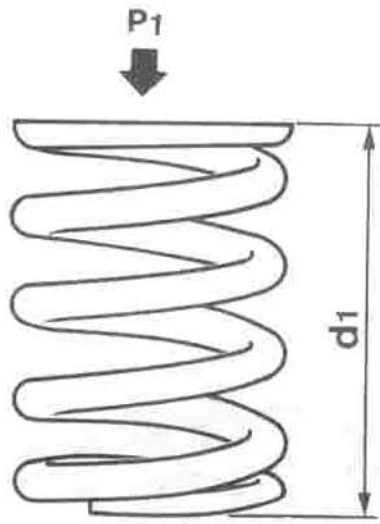
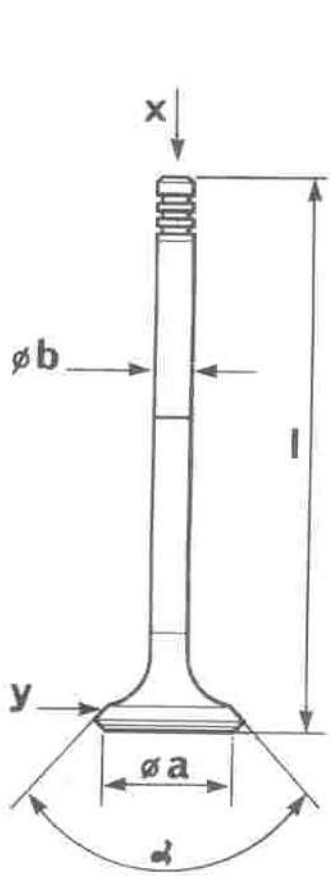

VALVES

⊗ : No machining is permissible

● : Faces (x) and (y) can be machined a maximum of 0,2 mm

	●	⊗
$l \pm 0,1$	104,48	103
$\varnothing a \begin{matrix} + 0 \\ - 0,2 \end{matrix}$	34,7	29,7
$\varnothing b \begin{matrix} 0 \\ - 0,015 \end{matrix}$	6,98	6,98
α	90°	90°

VALVE SPRINGS

	Grey
P1 : da.N	39,24
d1 : mm	38,8
P2 : da.N	80,93
d2 : mm	29,6

CAMSHAFTS

The INLET camshaft has a keyway (c) at the distributor end





CAMSHAFT GEARS

Depending on the emission standard, the gears are identified by the figure 2 or 3 engraved at (d).

	●	⊗
XU9J4	2	2
XU9J4Z	3	2

	β
2	133°20'
3	131°50'

VALVE GUIDES

	⊗	●
$\varnothing a \rightarrow 0$	12,034 + 0,039 + 0,028 or 12,13	12,034 + 0,039 + 0,028 or 12,13
 1	12,29	12,29
 2	12,59	12,59
	} - 0,011	} - 0,011
$\varnothing b \rightarrow 0$	12 or 12,055	12 or 12,055
 1	12,215	12,215
 2	12,515	12,515
	} + 0,027 0	} - 0,011
c	45,3 ± 0,5	46,94 ± 0,5
d	7 + 0,022 0	

The diameter d is obtained by machining after fitting in the cylinder head

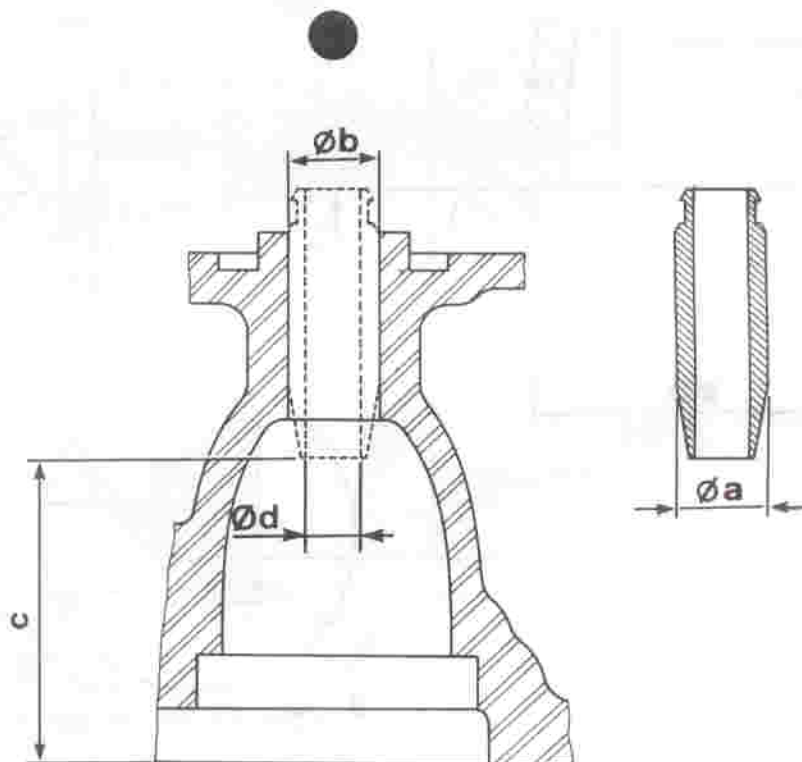
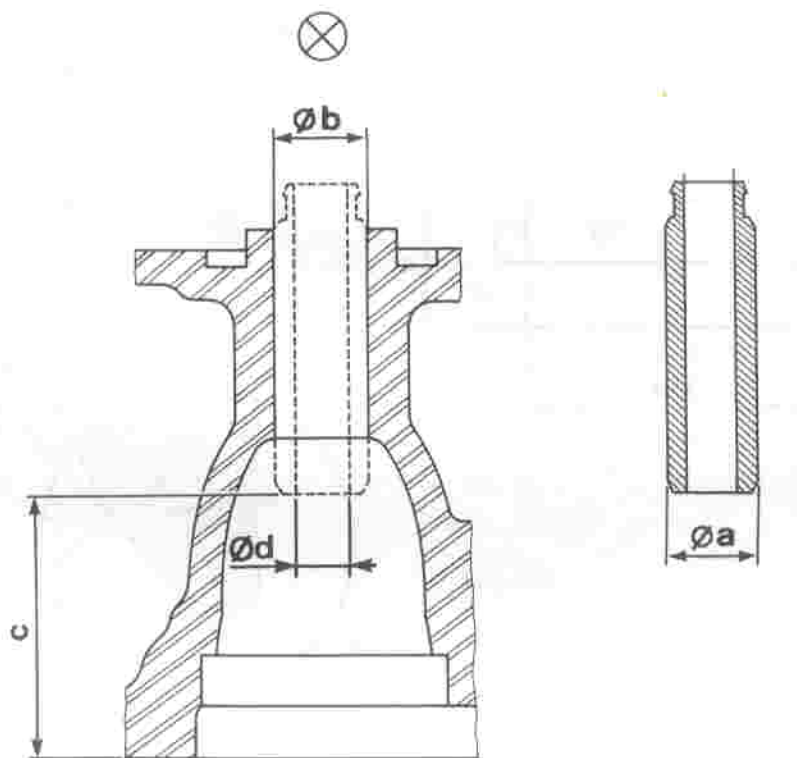



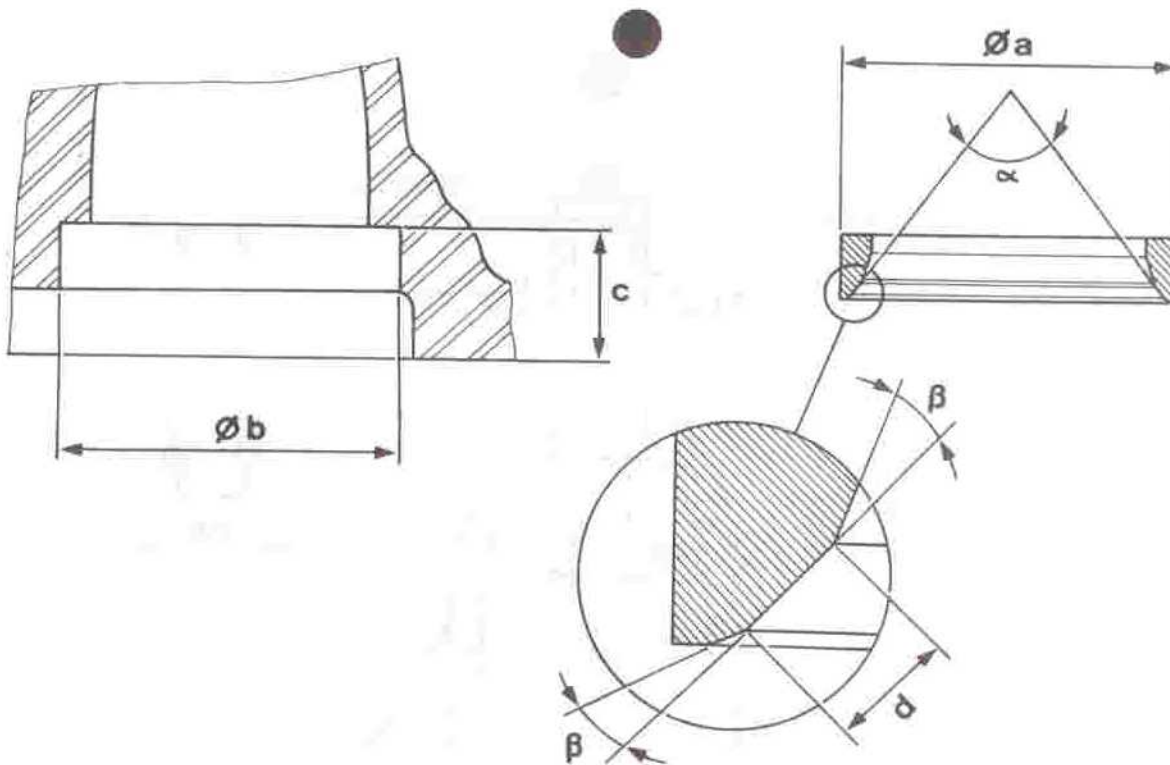
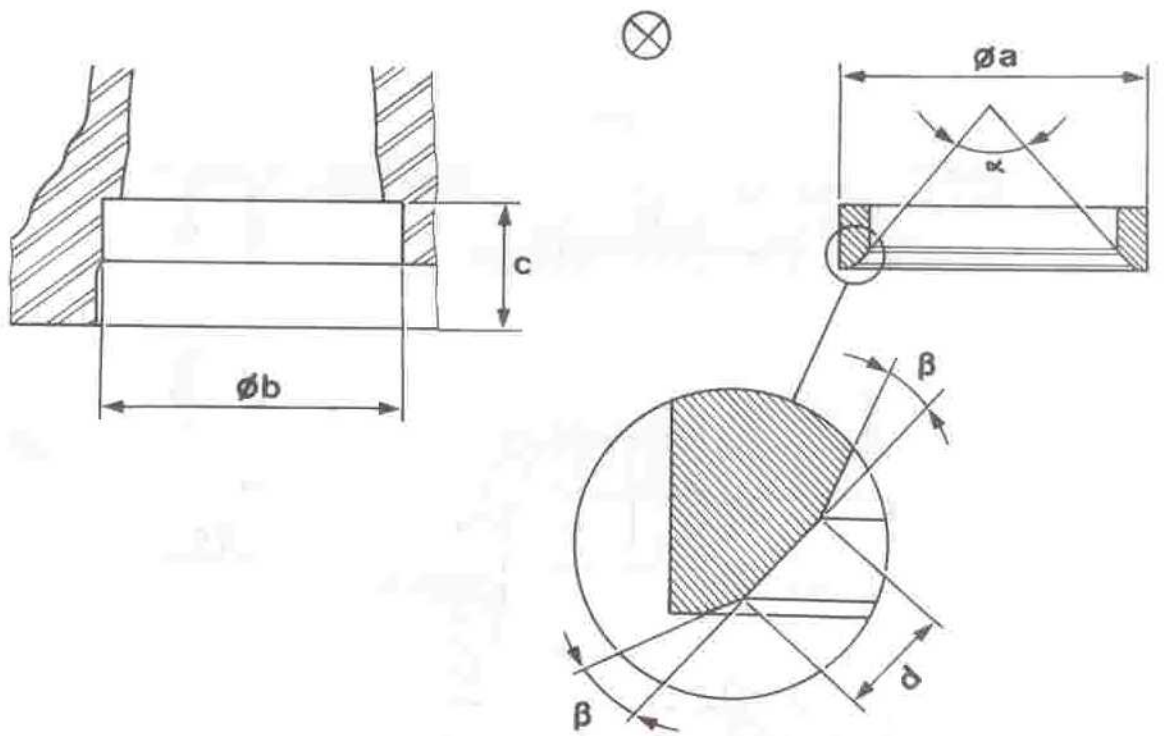



XU9J4



VALVE SEATS

Material : Steel

	⊗	●
$\varnothing a \begin{array}{ l} \hline \rightarrow 0 \\ \hline \end{array}$	31,57 or 31,77	36,373 or 36,573
	+ 0,105 + 0,080	+ 0,119 + 0,080
 1	31,87	36,673
 2	32,07	36,873
$\varnothing b \begin{array}{ l} \hline \rightarrow 0 \\ \hline \end{array}$	31,50 or 31,70	36,30 or 36,50
	+ 0,039 0	+ 0,039 0
 1	31,80	36,60
 2	32	36,80
$c \begin{array}{ l} \hline > 0 \\ \hline \end{array}$	15,49 or 15,59	15,74 or 15,84
	+ 0,2	+ 0,2
 1	15,69	15,94
 2	15,79	16,04
d	2,2 - 0,4	1,50 - 0,4
α	90°	90°
β	15°	15°

NOTE : When a seat is replaced, machine the inner diameter, if necessary, to line up with the port in the head

PISTONS

- (a) piston grade identification.
- (b) engine type identification :
 - XU9J4 : letter Z
 - XU9J4Z : letter X

LINERS

- (c) liner grade identification.

PISTON/LINER MATCHING

The liner bore sizes shown in the table below are the average of three measurements taken at the heights indicated in the illustration opposite

	$\varnothing d$	$\varnothing e$
A	82,963 - 82,977	83 - 83,01
B	82,973 - 82,987	83,01 - 83,02
C	82,983 - 82,997	83,02 - 83,03

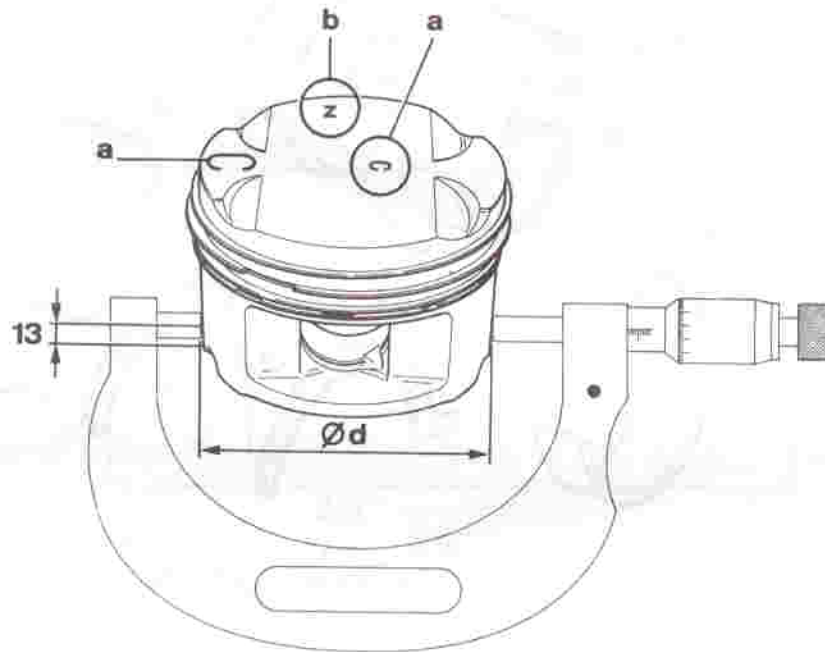

9-5-88 C68

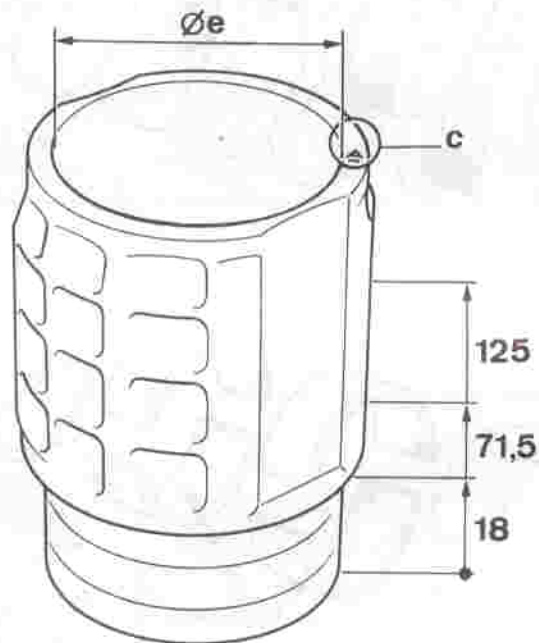

9-5-88 C70

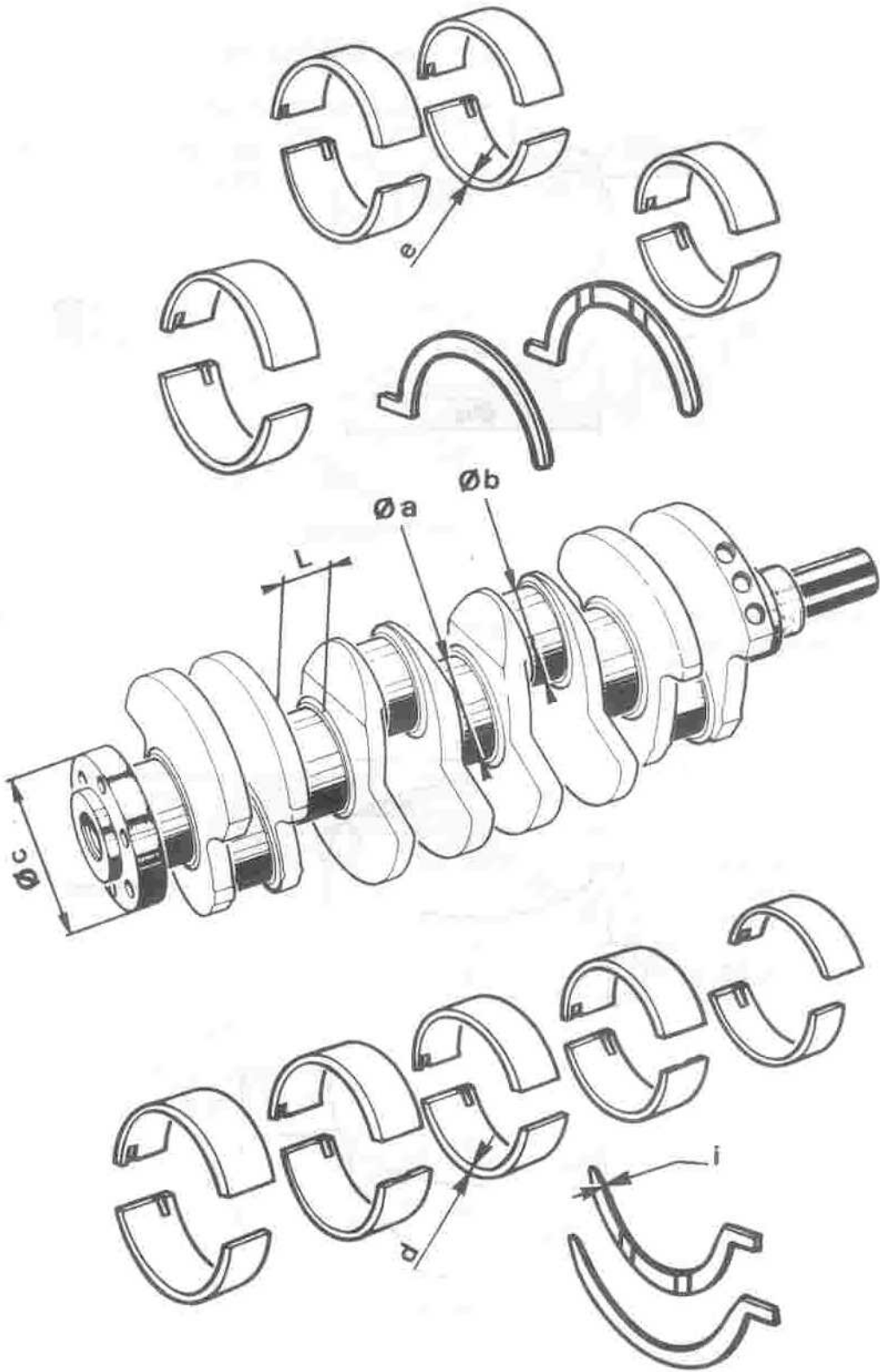

XU9J4



CRANKSHAFT

End float

- End float is between 0,07 and 0,27 mm., adjusted by four half shells

	L	i
$\text{H} > 0$	26,6 or 26,7	2,33 to 2,38 2,38 to 2,43 2,43 to 2,48 2,48 to 2,53
 1	26,8	
 2	26,9	
 3	27	

+ 0,05
0

Crank journals and main bearing shells

	$\varnothing a$	d
$\text{H} > 0$	60	1,842
 1	59,7	1,992

0
- 0,016

± 0,003

Big ends and bearing shells

	$\varnothing b$	e
$\text{H} > 0$	50	1,828
 1	49,7	1,978

0
- 0,016

+ 0,15

Oil seal contact surface

	$\varnothing c$
$\text{H} > 0$	90
 1	89,8

0
- 0,054

The main bearing shells $\text{H} > 0$ are identified by green or yellow marking

SPECIAL TOOLS**(-).0132**

- A1Z - Liner retaining clamp
- B - Liner adjustment plate
- C - Dial gauge support

(-).0118

- Dial gauge mounting comprising :
 - EZ - Support rod
 - FZ - Dial gauge carrier

(-).1504

- Dial gauge with attachment eye

(-).0153

- A1 - Universal tool for fitting main bearing seals
- A2 - Set of shims 0,15 mm thick
- B - Oil seal fitting plugs
- K - Oil seal fitting plugs
- L - Oil seal fitting plugs
- G - Crankshaft setting rod
- J - Four bolts 11 x 1,50 mm
- M - Two timing gear setting rods

(-).0213

- Clutch plate centralising mandrel

SEEM.C.TRONIC 87

- Equipment for measuring belt tension

TOOLS TO BE MADE LOCALLY**0.0149**

- Cylinder head releasing lever

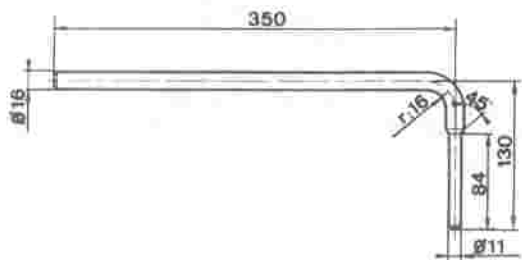

0.0149

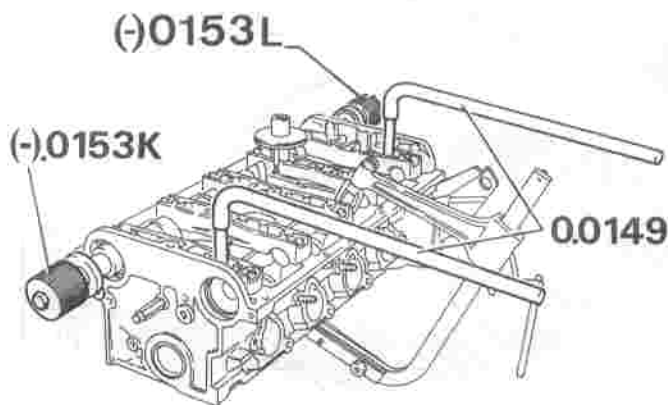

20-5-88 C3

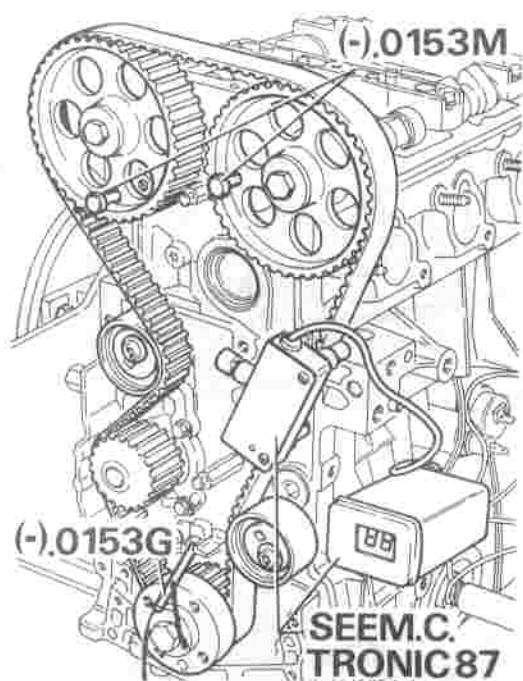

20-5-88 C2

SEEM.C.
TRONIC87

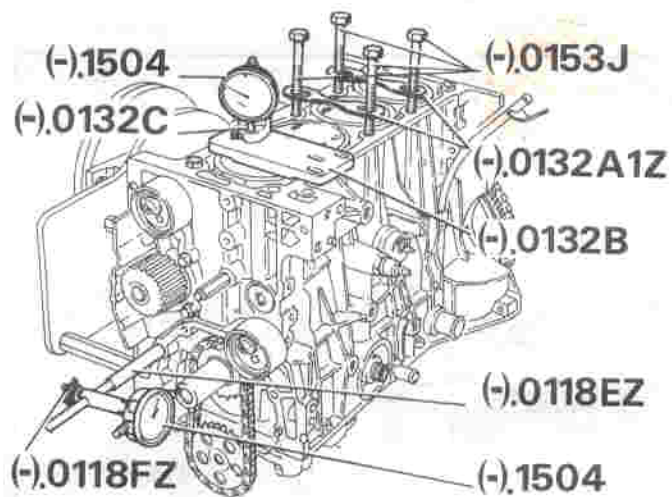

20-5-88 C6

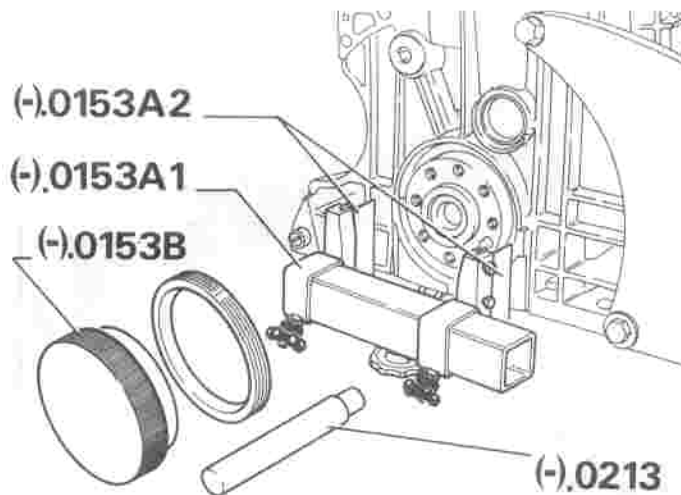

20-5-88 C7

XU9J4

I

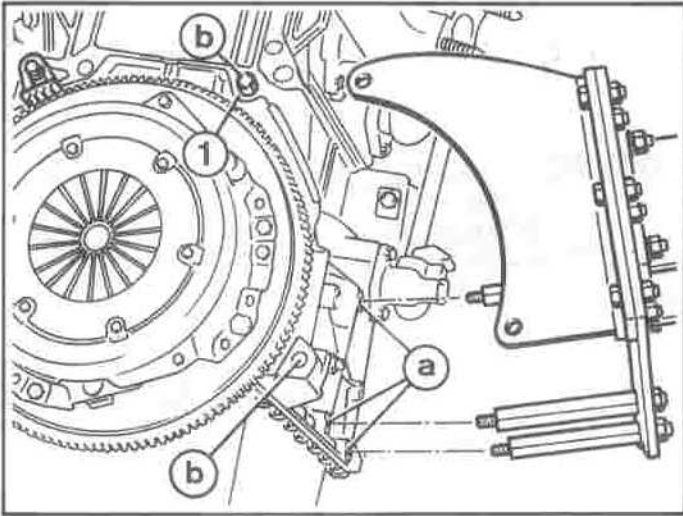

II

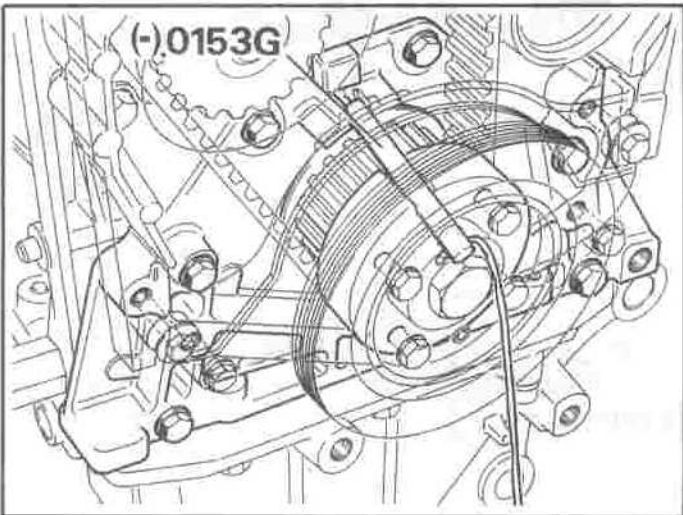

9-5-88 C30-C31-C38

III

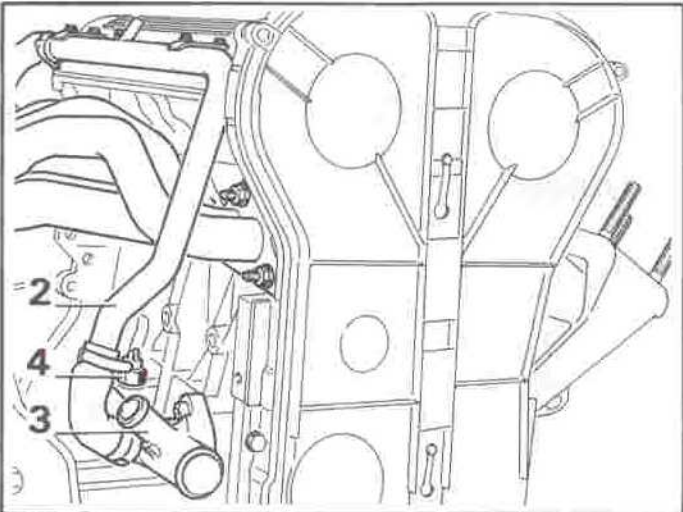

9-5-88 C89

IV

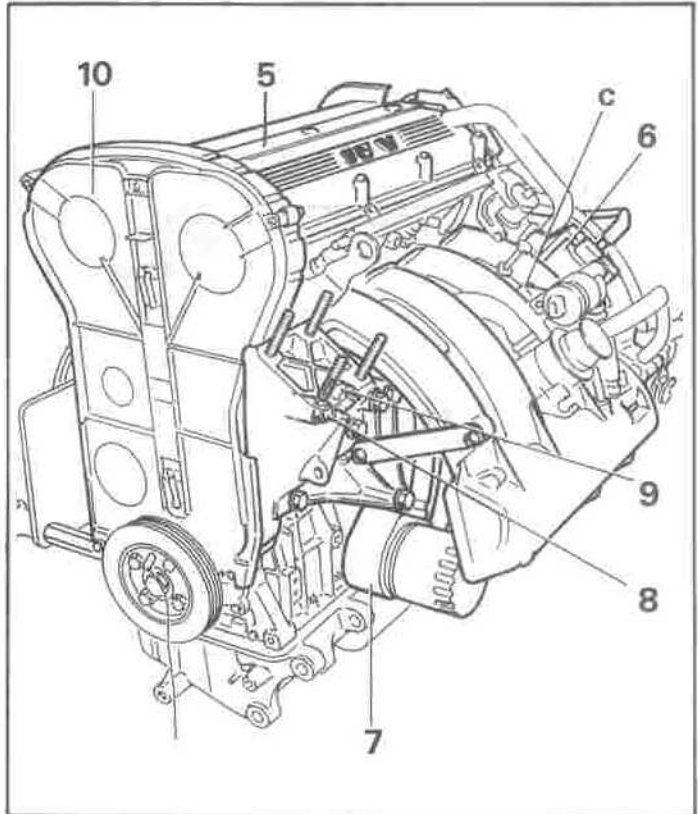

9-5-88 C34-C36

V

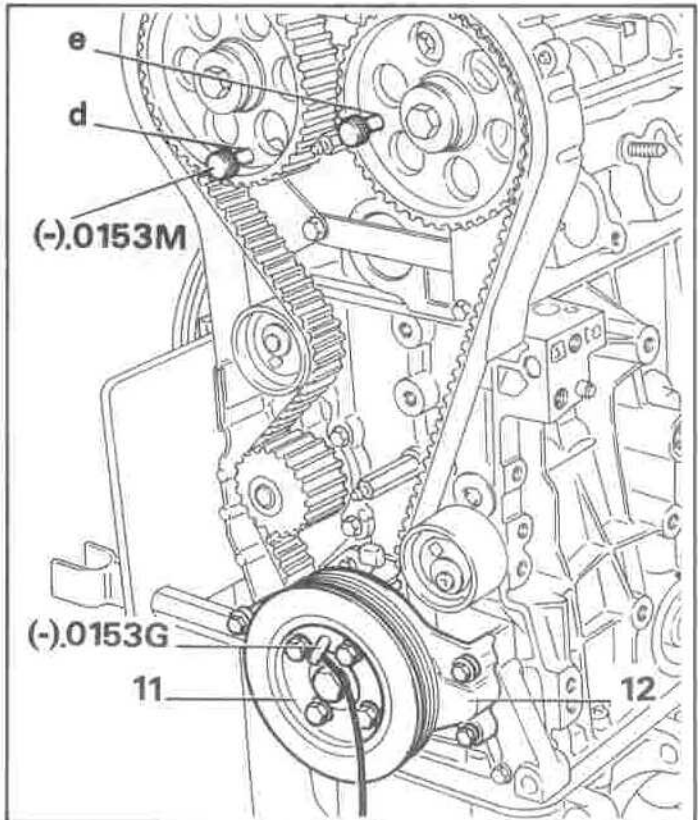

9-5-88 C41

I

- Remove the centralising dowel (1)
- Attach the engine to the DESVIL stand (reference 175/3) at (a) and (b)

II

- Position the flywheel with rod (-).0153 G
- Lock the flywheel with a tool of FACOM D86 type (fig. I)

III

- Remove :
 - the pipe (2) and the coolant inlet union (3)
 - the exhaust manifold and gaskets
 - the oil level sensor (4)

IV

- Remove :
 - the strip (5)
 - the ignition harness
 - the cylinder head cover
 - the alternator
 - the ignition coil (6)
 - the dipstick tube fixing at (c)
 - the inlet manifold and its gaskets
 - the intermediate engine mounting
 - the oil filter cartridge and the cooler (7)
 - the pressure switch (8) and the oil pressure sensor (9)
 - the timing cover (10)

V

- Remove :
 - the rod (-).0153 G
 - the pulley (11)
 - the lower timing cover (12)
- Position the camshaft gears with rods (-).0153 M at (d) and (e)

I

TIMING BELT REMOVAL

- Slacken the bolts (1) and (2)
- Remove :
 - the toothed belt
 - the bolt (3) and its washer
 - the gear (4) and its key
 - the oil pipe (5)

IV

- Remove :
 - the bolt (10)
- NOTE : Lock the camshaft with an open-ended spanner at (a)
- the pulley (11)
- the half cover (12)

IV

- Remove :
 - the distributor cap (13)
 - the rotor (14)
 - the bolt (15)
 - the rotor support (16)
 - the sealing plate (17)

II

- Release the bolts (6)

NOTE

Lock the camshaft with an open-ended spanner at (a) (fig. III)

- Remove :
 - the rods (-).0153 M
 - the camshaft gears and their keys
 - the cover (7)
 - the coolant pump (8)
 - the tensioning rollers
 - the oil pump gear spacer (9)

V

- Remove :
 - the thermostat housing cover (18)
 - the thermostat (19)
 - the thermostat housing (20)

I

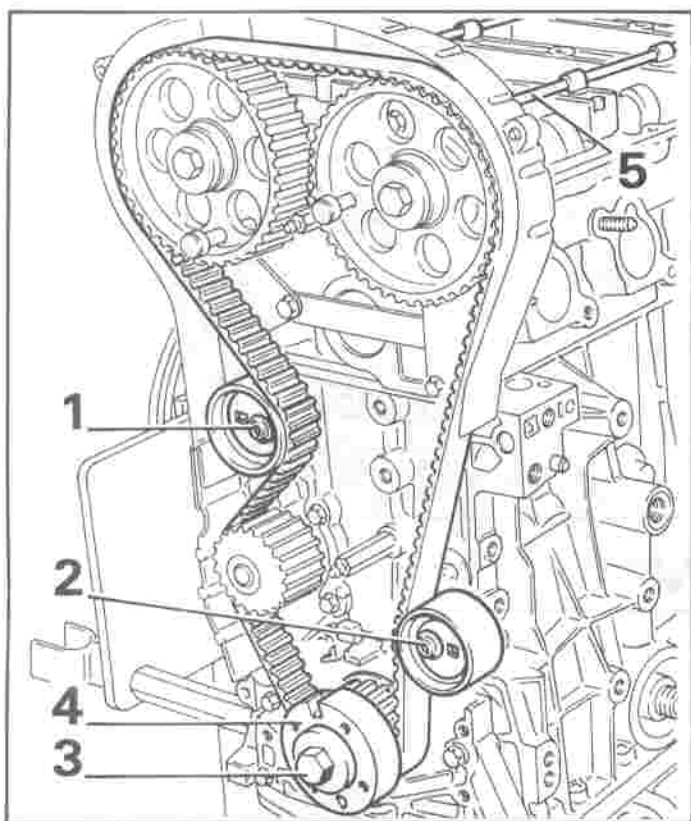

9-5-88 C23

III

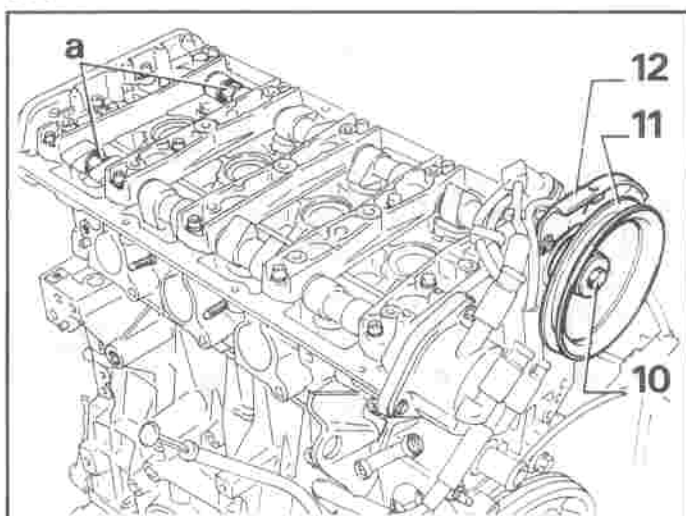

9-5-88 C40

II

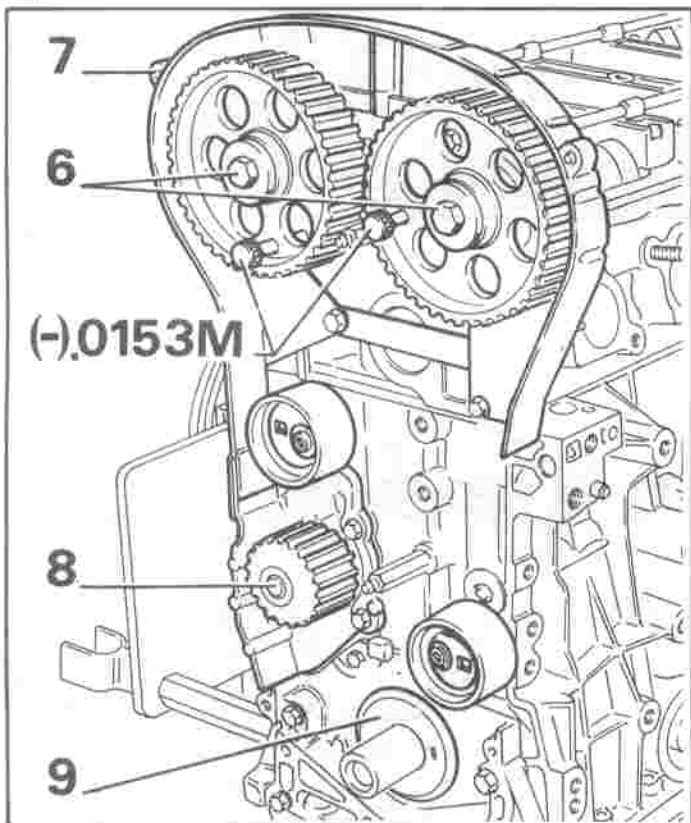

9-5-88 C25

IV

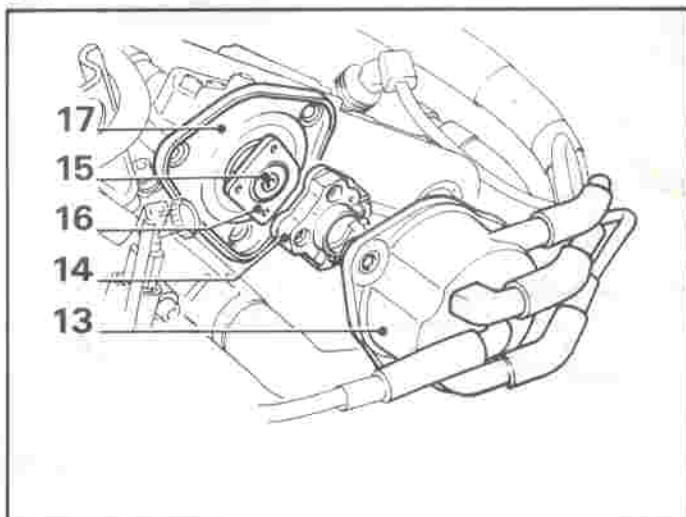

V

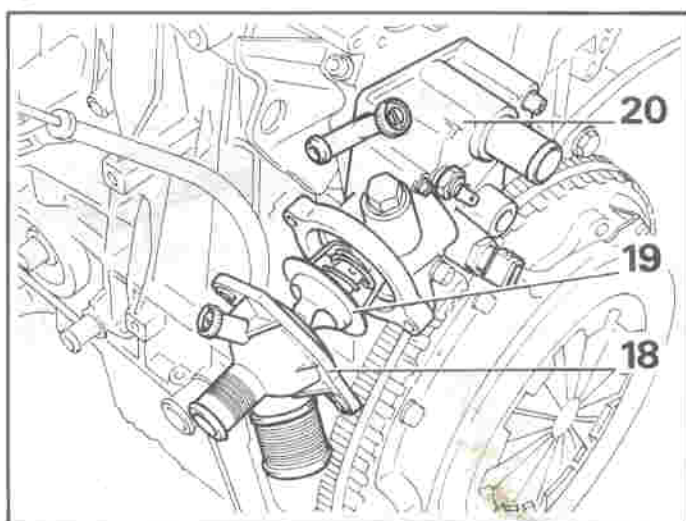

9-5-88 C28

XU9J4

I

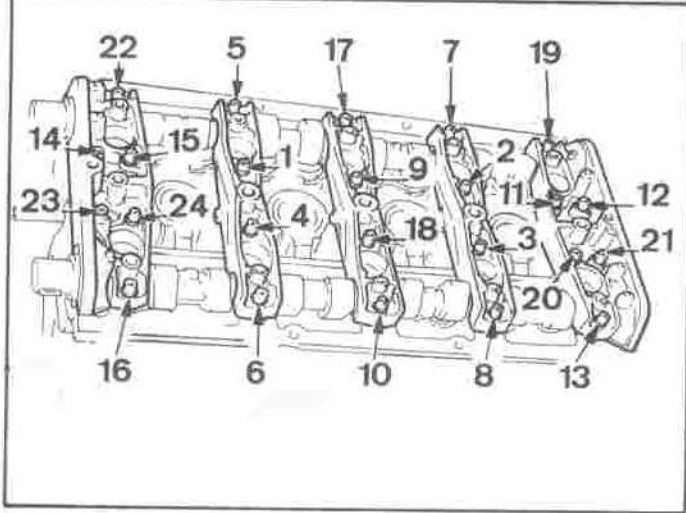

IV

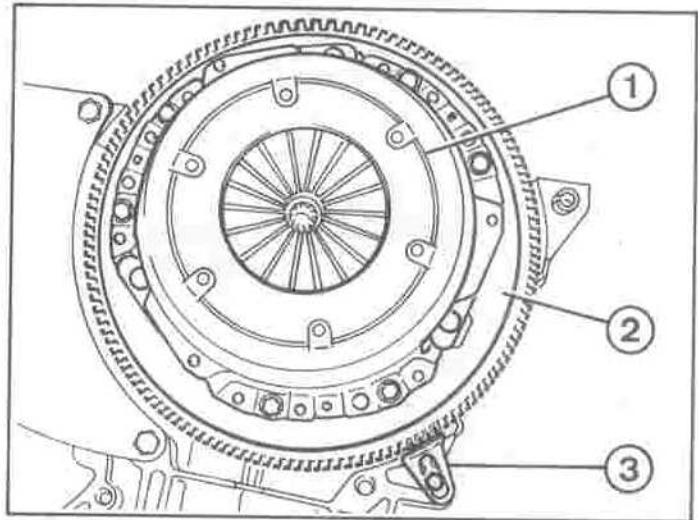

II

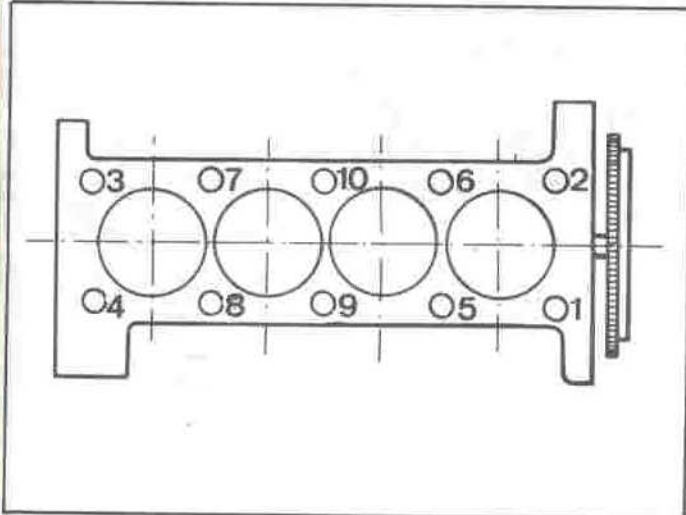

V

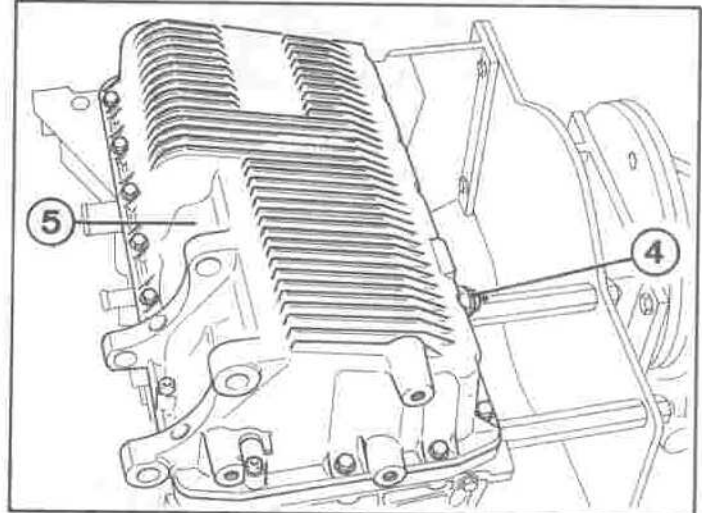

9-5-88 C52

III

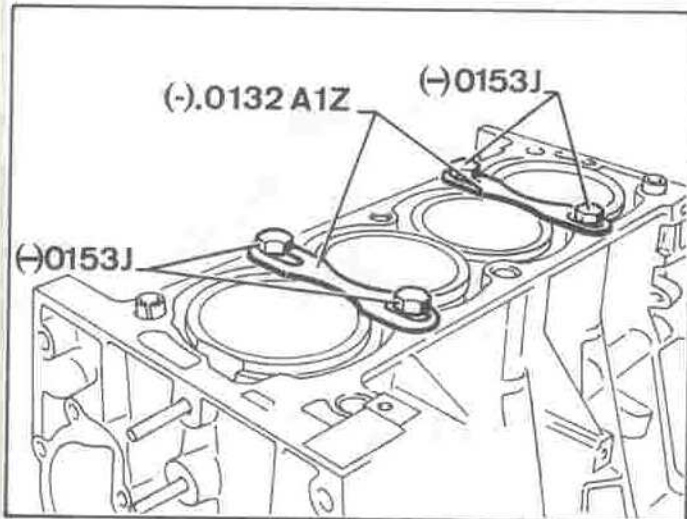

VI

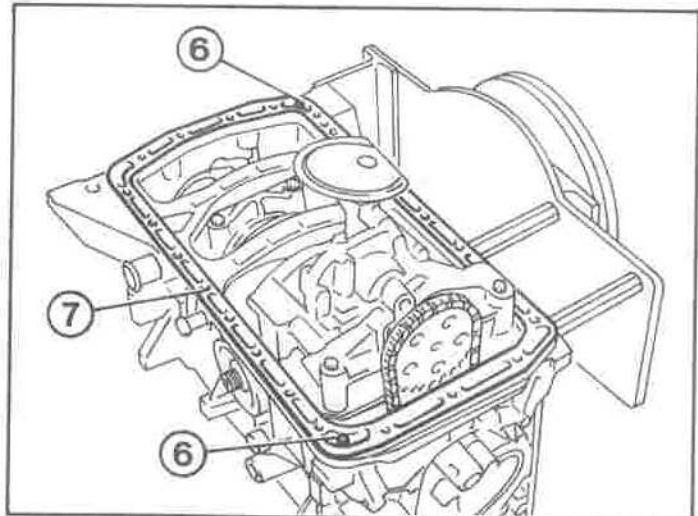

I

- Progressively uncrew in the order shown the camshaft bearing cap bolts
- Remove :
 - bearing caps no.4 and 2 then 3-1 and 5
 - the oil seals
 - the camshafts

IV

- Remove :
 - the clutch mechanism and plate (1)
 - the flywheel (2)
 - the flywheel locking tool (3)

II

- Progressively unscrew in the order shown the cylinder head bolts
- Retrieve the distance pieces under the bolt heads
- Using levers 0.0149 (see tooling page), rock the cylinder head to release it
- Remove the cylinder head and gasket

V

- Remove :
 - the oil temperature sensor (4)
 - the sump (5)

III

- Fit the liner retaining clamps (-).0132 A1Z using bolts (-).0153 J

VI

- Remove :
 - the two bolts (6)
 - the spacer (7)

I

- Remove :
- the oil seal carrier plate (1)
- the bolts (2), (3) and (4)

WARNING

The bolt (2) serves to centralise the pump (5)

IV

IMPORTANT

Mark the bearing shells with their positions

- Withdraw :
- the oil seal (10)
- the crankshaft
- the main bearing shells
- the thrust half washers (11)

II

- Remove :
- the shim (6)
- the assembly of pump (5), drive chain and sprocket (7)

V

- Remove :
- the piston lubrication pipes (12)
- the liner retaining clamps (-).0132 A1Z
- the piston-liner assemblies

NOTE

If the liners are to be re-used, mark their positions in the block

III

- Remove :
- the big end nuts
- the main bearing bolts
- the two centre main bearing nuts (8)
- the two side bolts (9)
- the big end caps
- the main bearing caps
- the thrust half washers from no. 2 main bearing cap

VI

- Remove :
- the gudgeon pin circlips
- the gudgeon pins

I

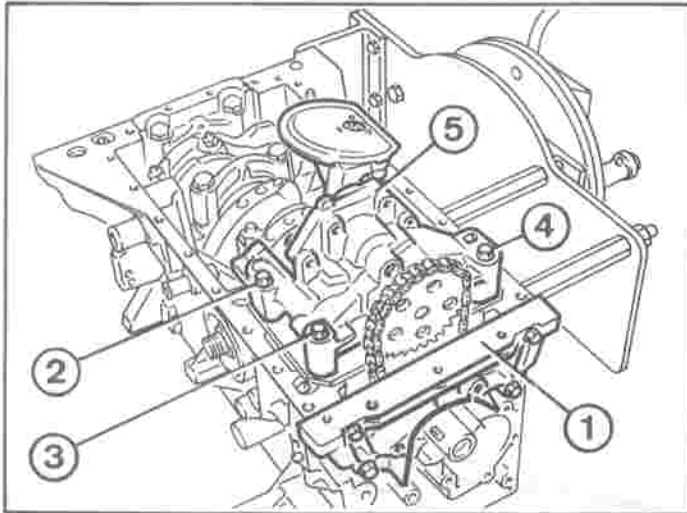

22-12-86 C36

IV

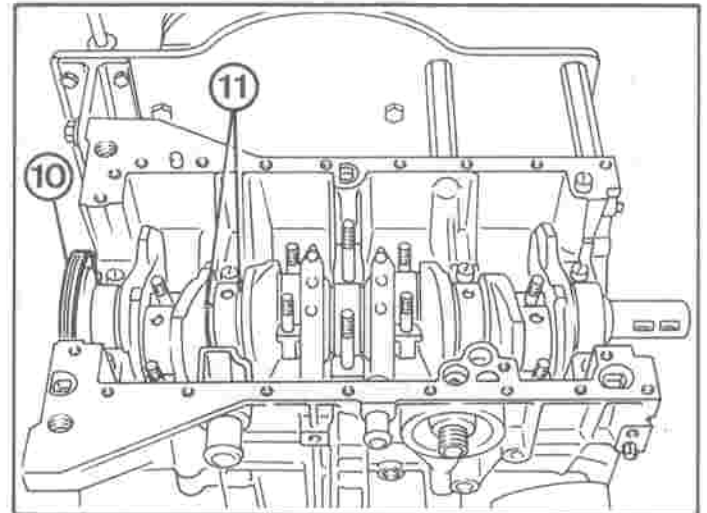

22-12-86 C47

II

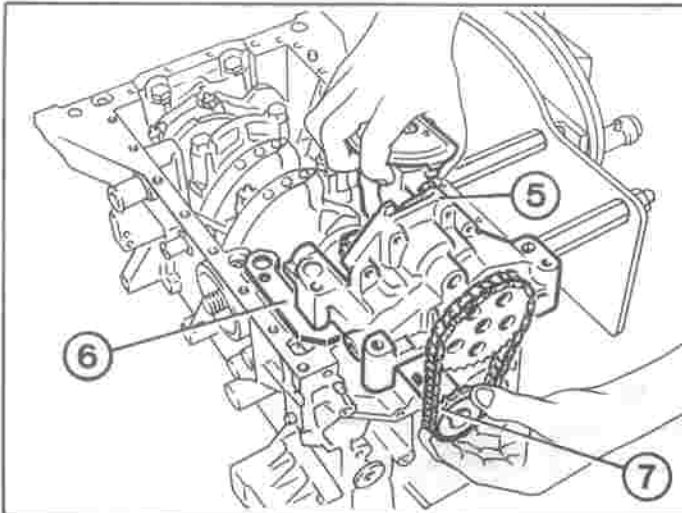

22-12-86 C42

V

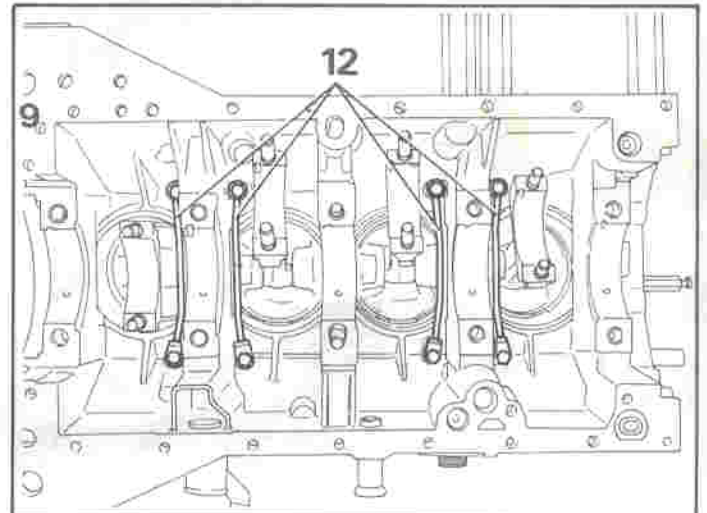

9-5-88 C54

III

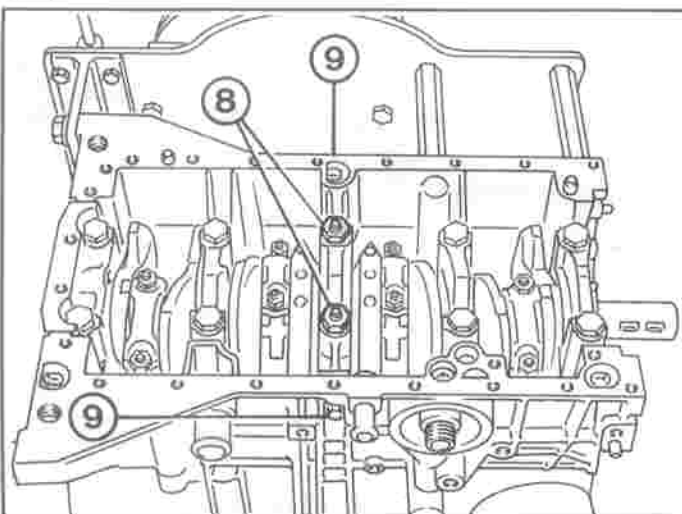

22-12-86 C46

VI

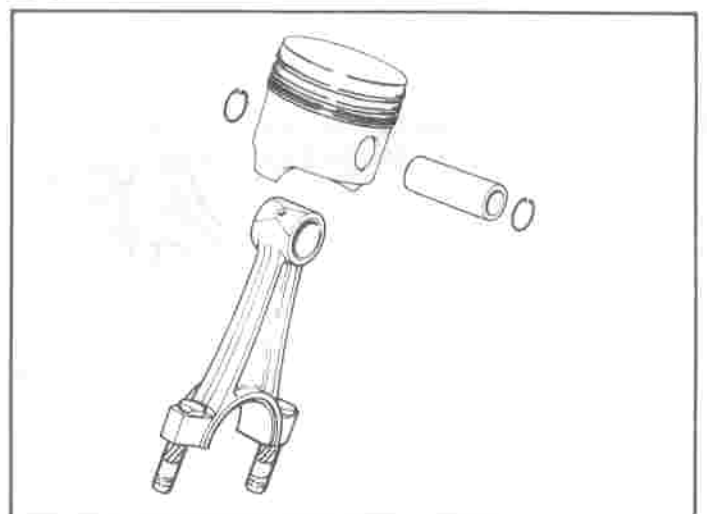

XU9J4

I

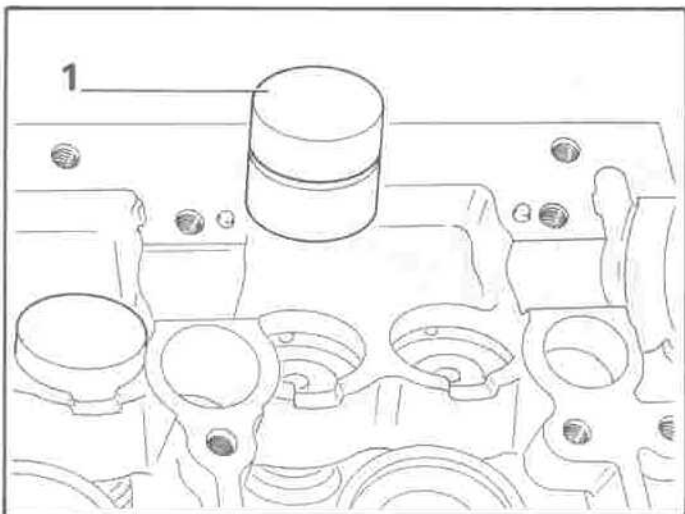

9-5-88 C45

II

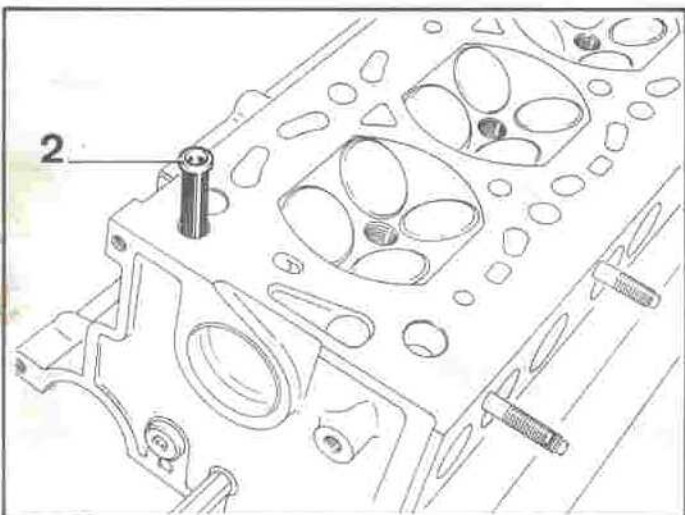

9-5-88 C73

III

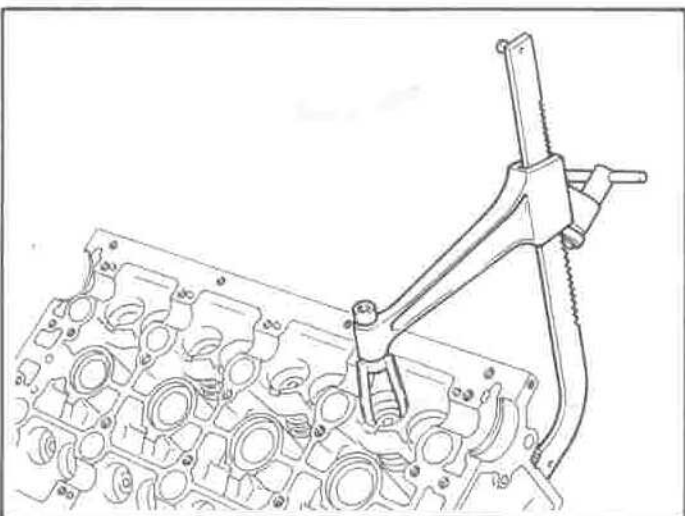

9-5-88 C49

IV

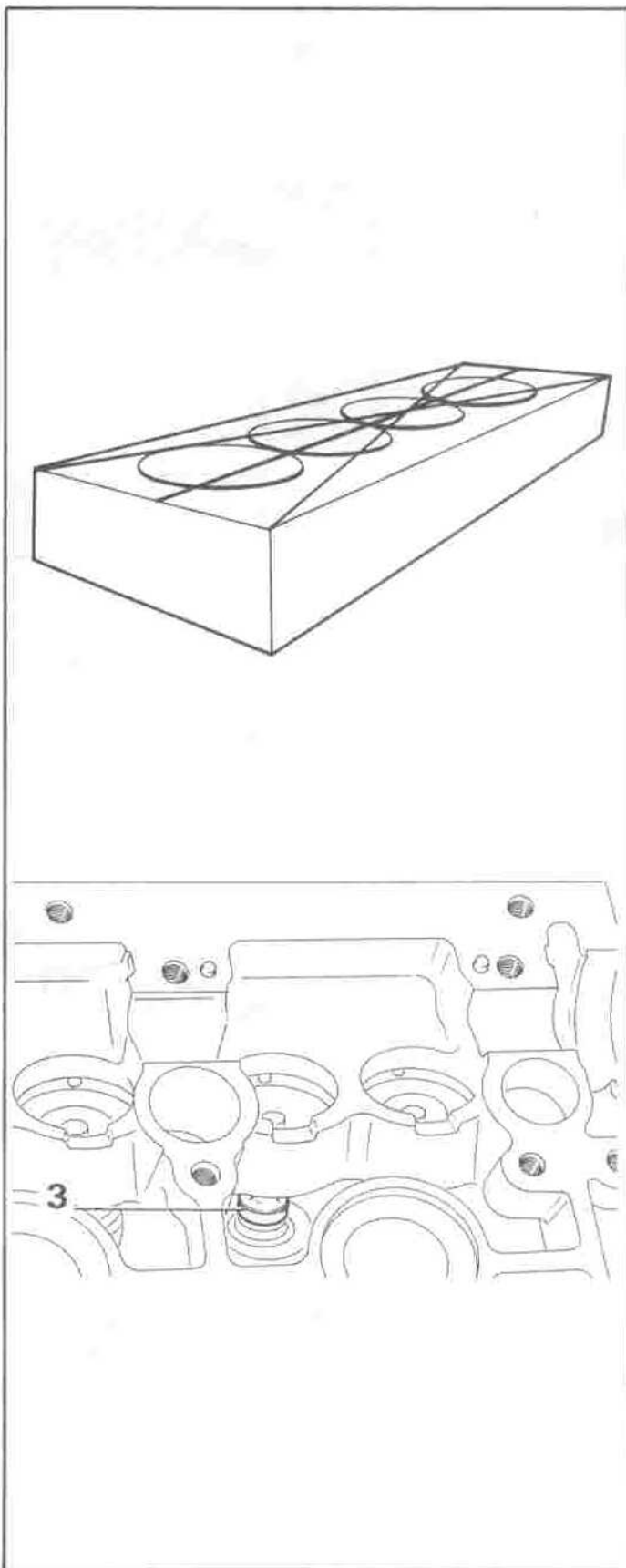

9-5-88 C48

I

CYLINDER HEAD

- Remove :
- the spark plugs
- the hydraulic tappets (1) marking their positions

II

- Using a small screwdriver, remove the filter (2)

III

- Remove :
- the valve springs, using a universal lifter of FACOM U13L type
- the valves
- the washers from the spring seats
- the valve stem seals

IMPORTANT

Take care not to scratch the tappet bores with the tool

IV

NOTE

To clean the joint faces, use DECAPLOC 82 varnish remover

- Check for bow :
 - maximum permissible bow : 0,05 mm
- Check the condition of :
 - the valve seats
 - the valve guides
 - the valves
 - the valves springs
 - the camshafts (journals, cams)
 - the camshaft bearings
 - the various tappings

IMPORTANT

For checking, rectifying or replacing these parts, see identification page

- lap in the valves
- fit new valve stem seals (3) using tool (-).0132 W

I

CYLINDER HEAD

- Refit the valves
- Insert a new filter (1)

III

- Fit the camshafts, positioning the keyways (6) and (7) at approximately three o'clock

NOTE

The INLET camshaft is identified by a keyway at the distributor end

- Fit nos. 2 and 4 bearing caps without tightening the bolts, then nos.5-1-3 caps

NOTE

Coat the joint faces of caps nos.1 and 5 with FORMATJOINT sealing compound

II

- Hydraulic tappets (2) :
 - remove the piston assemblies by tapping the tappet on a block of wood
 - depress the ball (4) to empty the chamber (5)

NOTE

Put oil in the low pressure chamber (a)

- oil the tappets bores
- fit the assembled tappets (2) in their respective bores

IV

- Tighten the bolts progressively in the order shown :
 - tightening torque : 10 Nm (7 lbf ft)

V

- Using tool (-).0153 K and a bolt (8), fit new camshaft oil seals (9)

NOTE

At the distributor end, use tool (-).0153 L

I

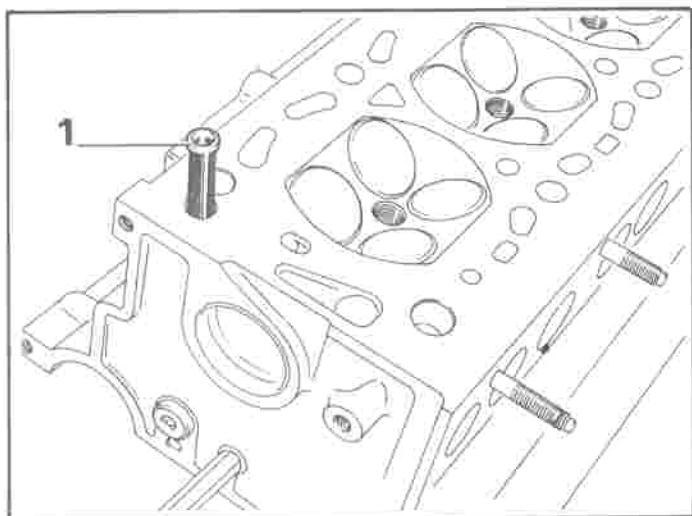

9-5-88 C73

III

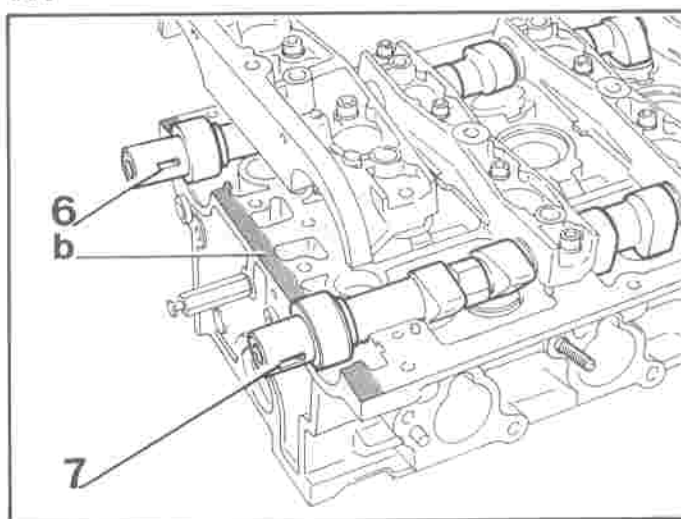

9-5-88 C63

II

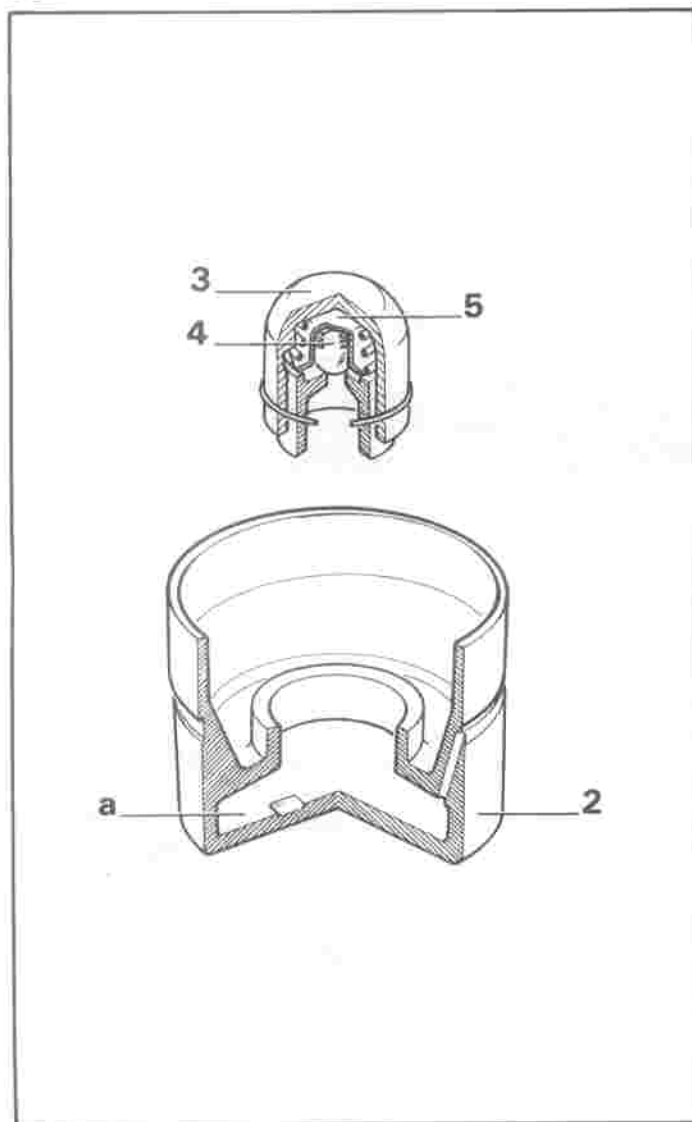

IV

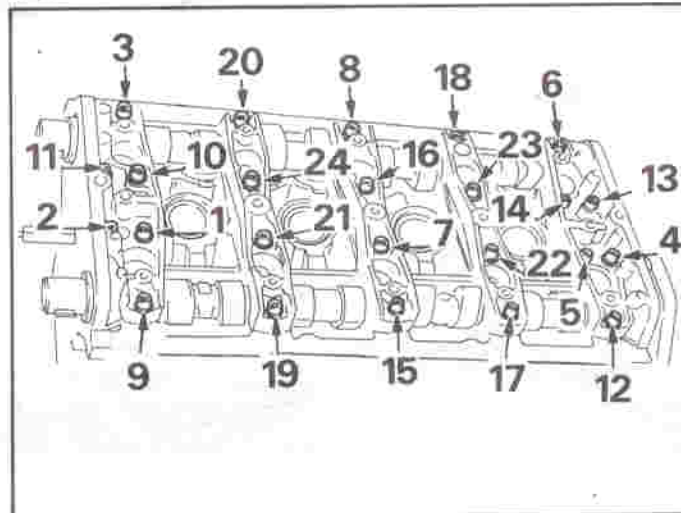

V

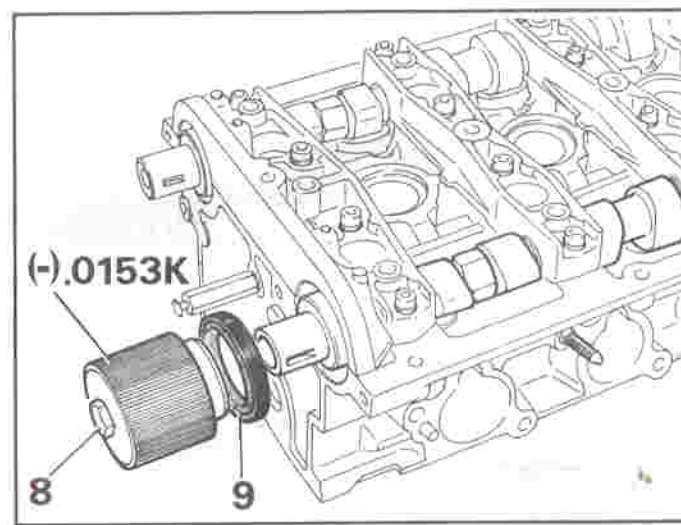

9-5-88 C62

I

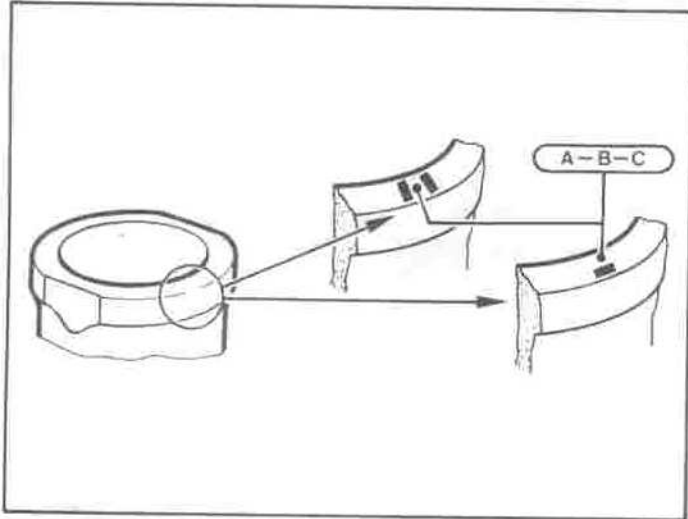

IV

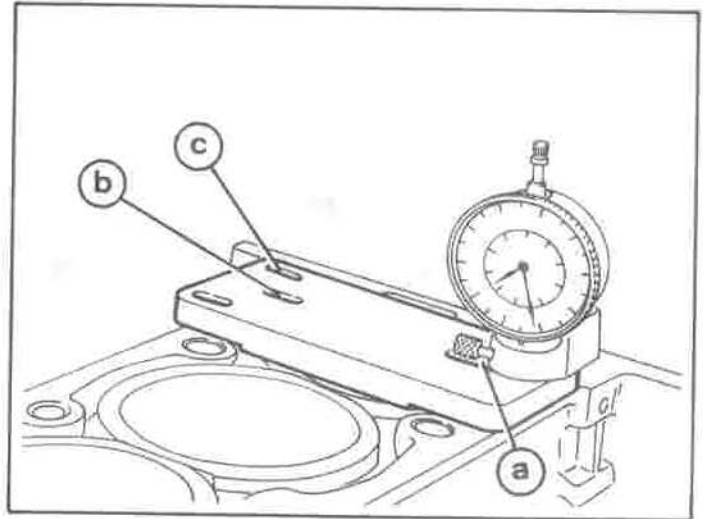

II

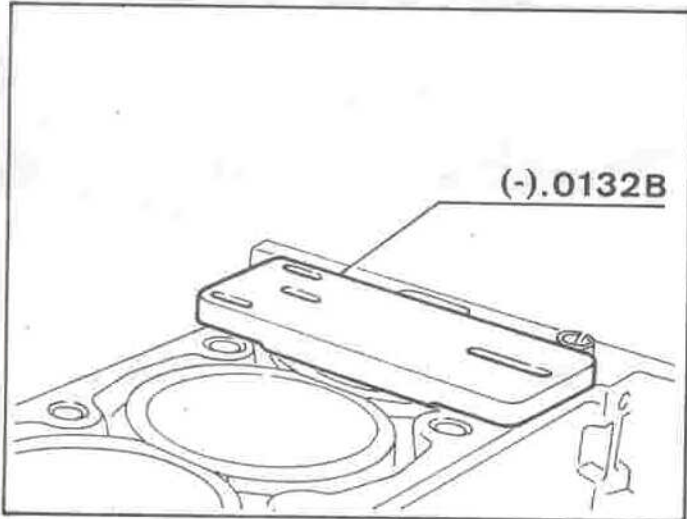

V

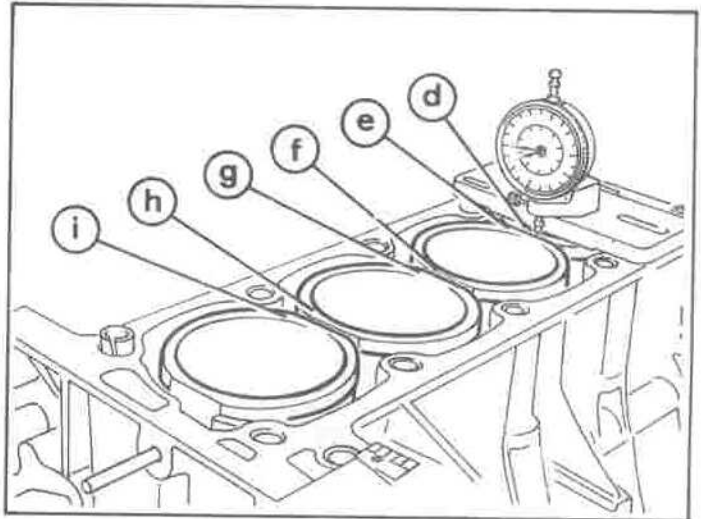

III

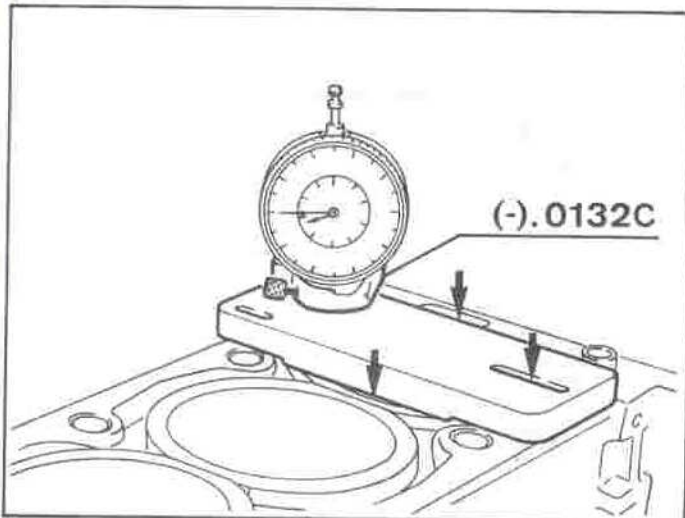

VI

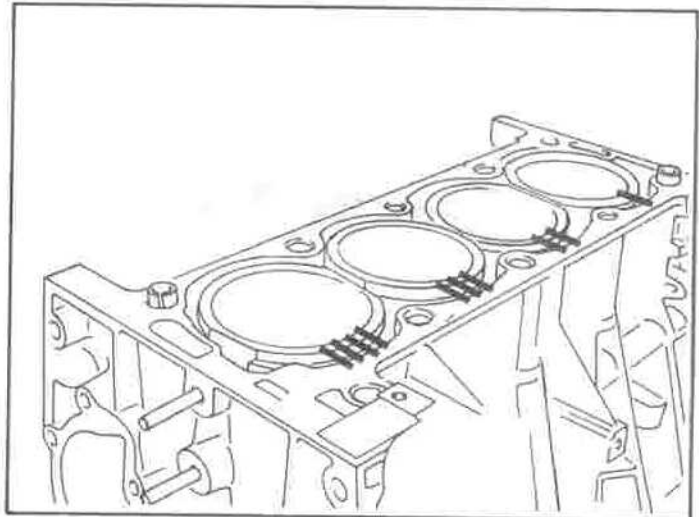

<p>I</p> <p>CHECKING LINER PROTRUSION</p> <p>In this assembly, the liners seat directly on the cylinder block, and their protrusion is obtained by the manufacturing dimensions of the block and liners</p> <p>The letters A, B and C are the grade identification (see identification page)</p>	<p>IV</p> <ul style="list-style-type: none"> - Measure the protrusion of the liner in relation to the block at three points (a), (b) and (c) <p>If the variation between the three points is more than 0,02 mm., rectify the cause</p> <ul style="list-style-type: none"> - The procedure is the same for each liner
<p>II</p> <p>NOTE</p> <p>If the liners are re-used, align the markings made on dismantling</p> <ul style="list-style-type: none"> - Fit : <ul style="list-style-type: none"> - the four liners - the plate (-).0132 B with the flat face upward 	<p>V</p> <ul style="list-style-type: none"> - Check the difference in level between the points (d) and (e) (f) and (g), (h) and (i) <p>Maximum difference in level : 0,05 mm</p> <p>NOTE</p> <p>With new liners, protrusion and level differences may be corrected by rotating half a turn</p>
<p>III</p> <ul style="list-style-type: none"> - Mount the dial gauge on the support (-).0132 C - Zero the dial gauge on the liner - Liner protrusion : 0,03 to 0,10 mm - Measure at four points : the variation must not exceed 0,02 mm. : if it does, rectify the cause 	<p>VI</p> <ul style="list-style-type: none"> - Mark the positions of the liners than remove them

I

ASSEMBLING PISTONS AND CONNECTING RODS

- Assemble the pistons to the connecting rods :
- **DIST** marking on the piston to the right
- notch (a) to the bottom
- Fit the gudgeon pin circlips with their gaps towards the piston rings

III

NOTE

- Position the piston in the liner so that on assembly :
- the markings on the liner and block coincide
- the arrows on the pistons are towards the timing gears

II

FITTING THE PISTON RINGS

- The rings must be free in their grooves when fitted

IMPORTANT

The face marked at (b) must be towards the top

Position the gap (c) of the SCRAPER RING (1) as shown opposite

SPACE THE GAPS OF THE TAPER RING (2) AND CHROMED RADIUSED RING (3) at 120° either side of the scraper ring gap (c)

- Oil the piston. Moderately tighten the ring clamp

IV

ASSEMBLING PISTONS AND LINERS

- Push the liner on the piston until the piston ring clamp is freed
- Proceed in the same way for the other three pistons

V

- Fit the sealing rings (4) without twisting them
 - Check that they are correctly positioned
 - Fit the big end bearing shells
- For bearing shell thickness, see identification page

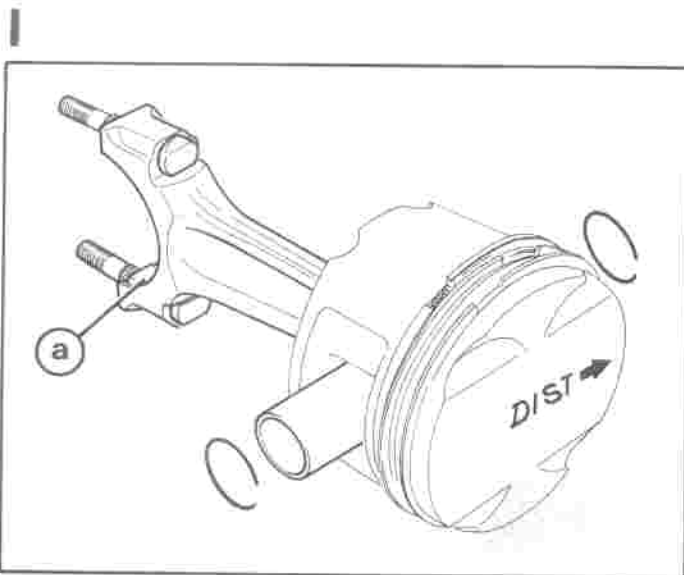

9-5-88 C66

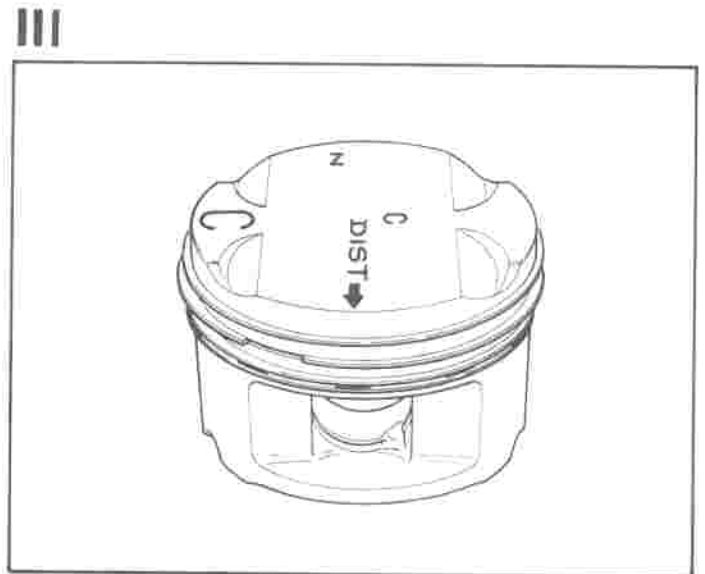

9-5-88 C68

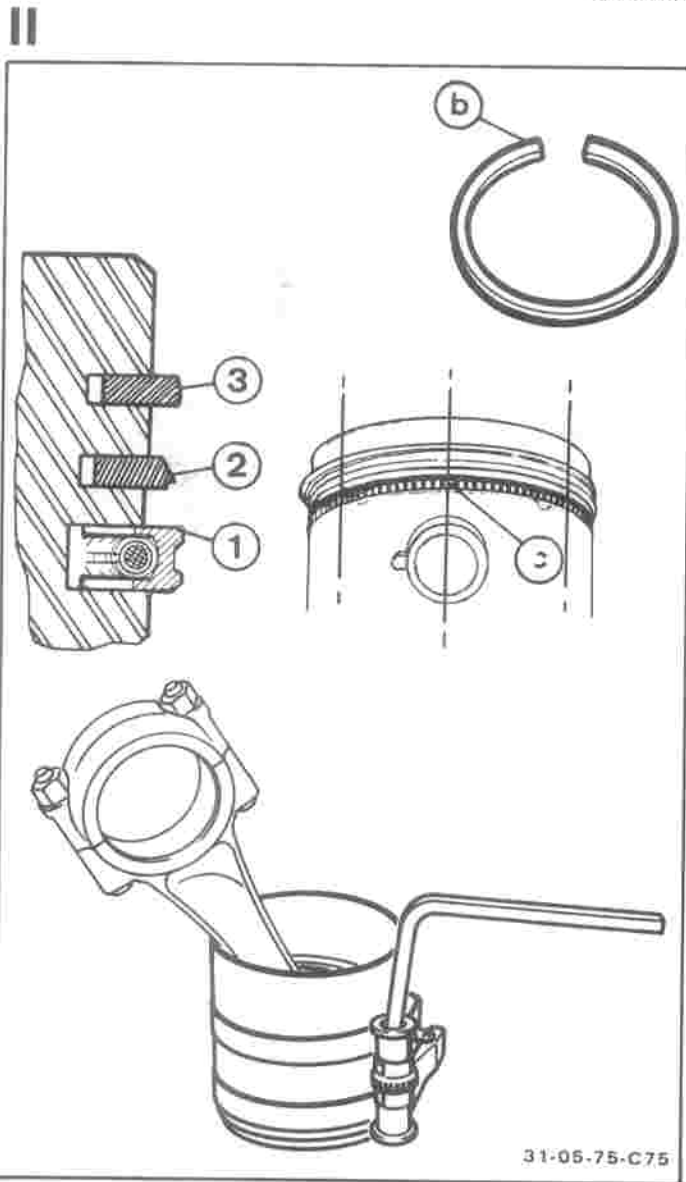

31-05-75-C75

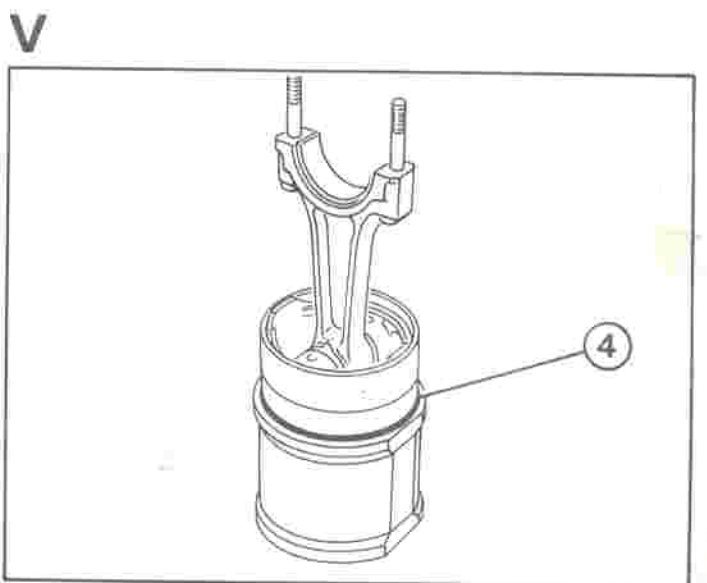
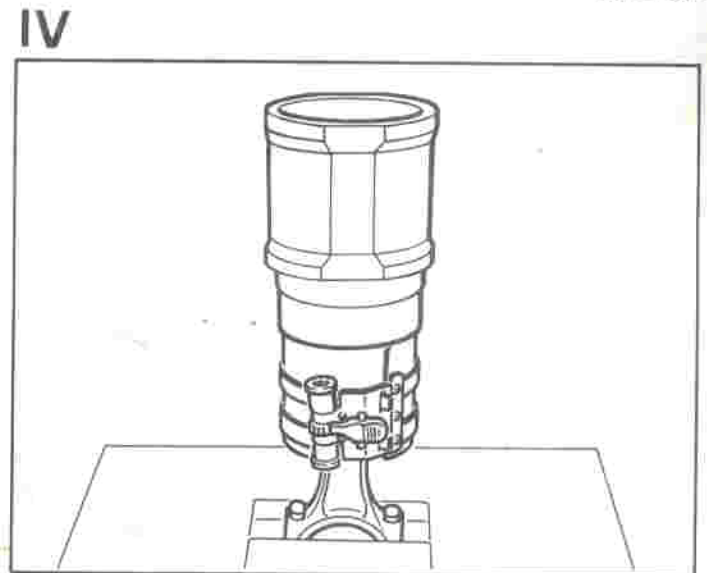

I

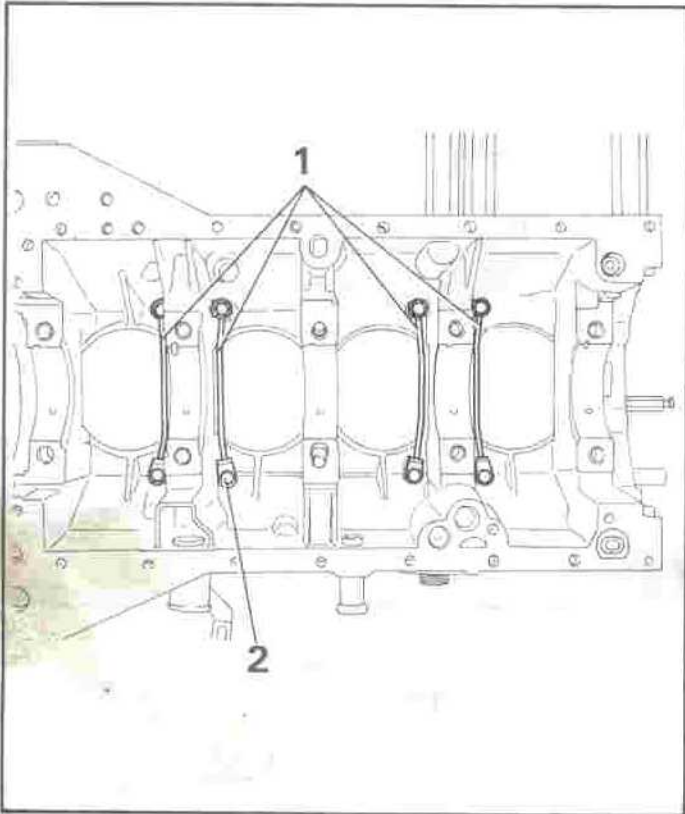

II

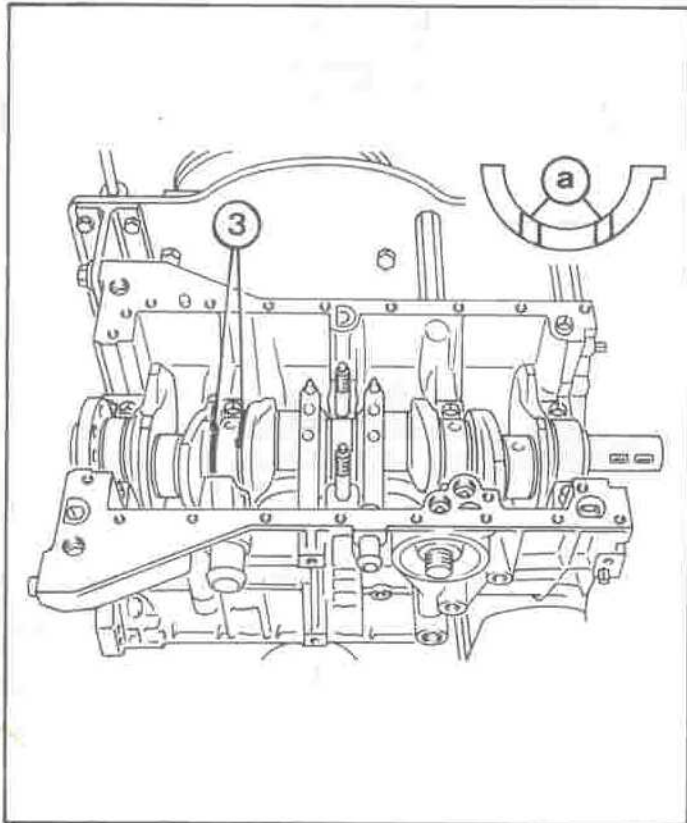

III

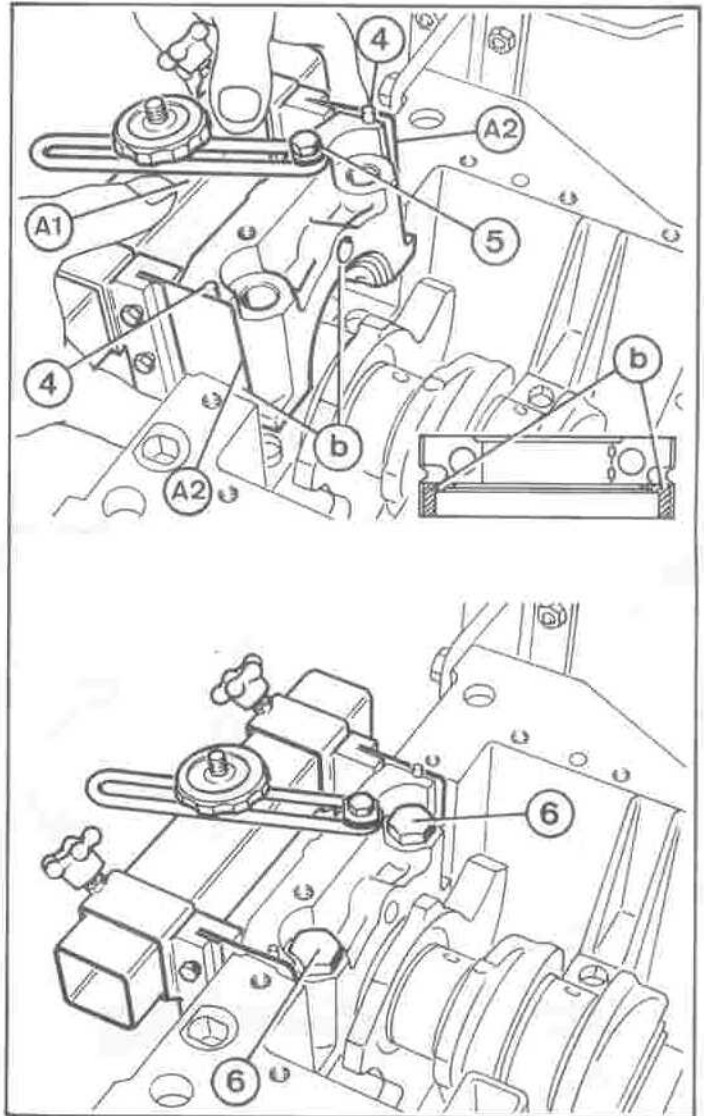

IV

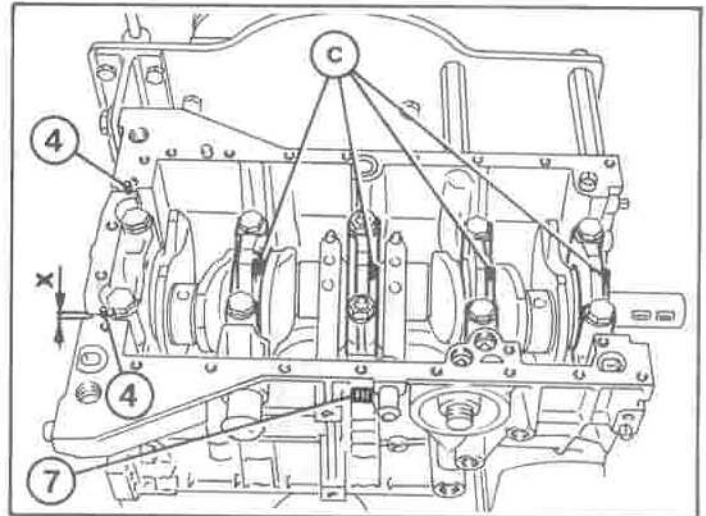

I

CRANKSHAFT

- Check the condition of the crankshaft :
 - the pins
 - the journals
 - the tappings
 - the keyway
- Fit the piston lubrication pipes (1)
- Coat the bolts (2) with THREADLOCK LOCTITE and tighten them to 10 Nm (7 lbf ft)
- Fit the main bearing shells according to their markings
- Oil
For bearing shell thicknesses, see identification page

II

- Fit :
 - the crankshaft
 - two thrust half washers (3)

NOTE

To select half washer thickness, identification page

- Oil, the grooved face (a) to the crankshaft

III

- Fit the side seals (4)
- Apply a thin coat of SILICONE CLASS 1 sealing compound to the surfaces (b)
- Attach tool (-).0153 A1, fitted with shims A2, using a bolt (5) and washer
- Oil the shims and the housing

WARNING

To avoid stretching the side seals, fit the bearing cap as follows :

- insert it into the housing at 45°
- straighten it
- lower it gently
- fit and tighten the two bolts (6)
- Remove the bolt (5) and withdraw the tool horizontally

IV

IMPORTANT

The main bearing caps are fitted with their notches (c) towards the timings gears

- Fit :
 - no.2 bearing cap with its two thrust half washers, grooved faces towards the crankshaft
 - nos.3-4-5 bearing caps and their shells according to the marking made on dismantling
- Tighten :
 - the bolts and nuts to 50 Nm (37 lbf ft)
 - the two side bolts (7) to 25 Nm (18 lbf ft)
- Check the protrusion of the seals (4) $x = 2$ mm.
- Cut back if necessary

I

CHECKING CRANKSHAFT ENDFLOAT

- Mount the dial gauge on the cylinder block at the timing gear end
- Push the crankshaft to one end
- Zero the dial gauge
- Push the crankshaft in the other direction : endfloat = 0,07 to 0,27 mm.

NOTE

- For thrust half washer thicknesses available, see identification page
- Correct the endfloat if necessary

IMPORTANT

All four thrust half washers fitted must be the same thickness

- Check that the crankshaft rotates freely

III

- Fit the piston/connecting rod/liner assemblies into their correct bores (markings on the liners in line with the markings on the block)
- Fit the clamps (-).0132 A1Z

NOTE

The connecting rods and their caps are matched and identified by dabs of paint

- Oil
- Fit the big end caps
- Pre-tighten the nuts to 40 Nm (30 lbf ft)
- Slacken the nuts then tighten to 20 Nm (15 lbf ft) followed by a further 70° tightening using a tool of FACOM D360 type

IV

- Fit :
 - the oil pump assembly (2), drive chain and sprocket (3) with the L-shaped shim at (4)
- Tighten the bolts (5), (6) and (7) to 20 Nm (15 lbf ft).

WARNING

The bolt (5) serves to centralise the pump

II

- Position a new oil seal (1) on tool (-).0153 B
- Oil
- Fit the seal by tapping fully home with a mallet
- Remove the tool with a turning movement

I

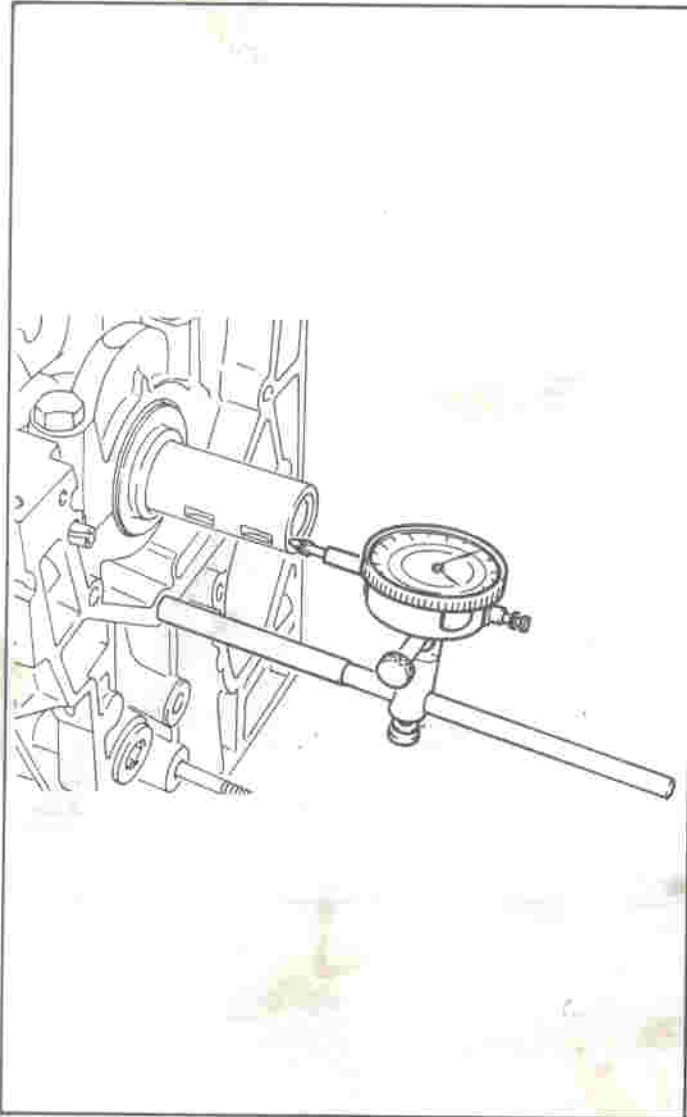

III

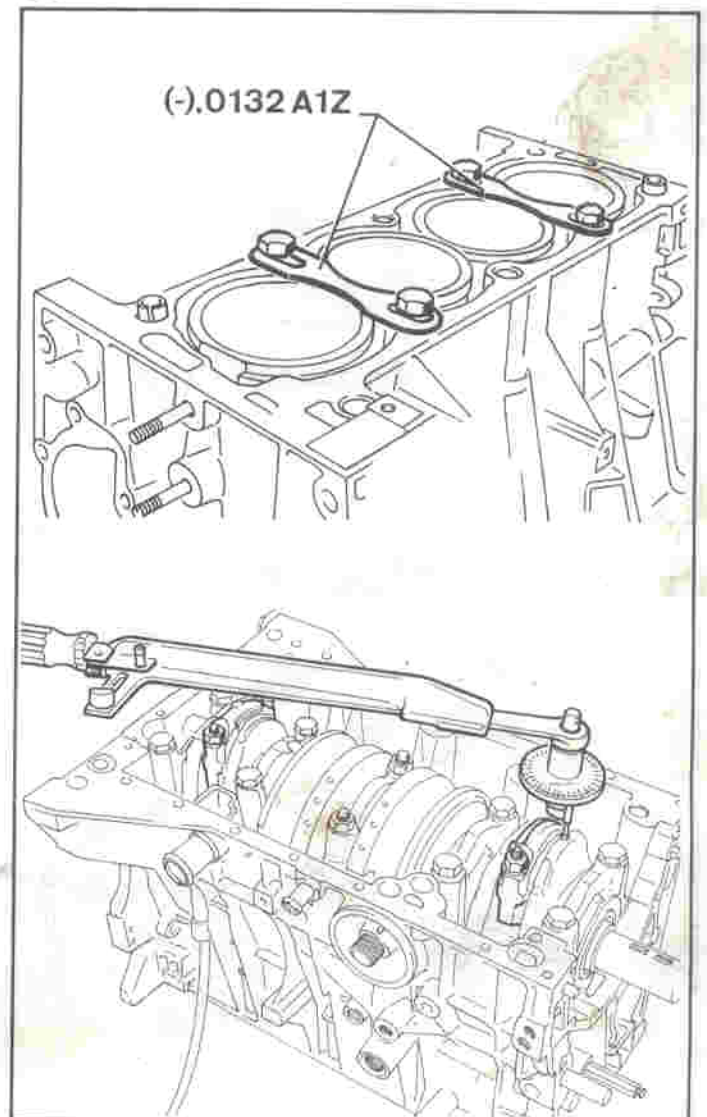

9-5-88 C85

II

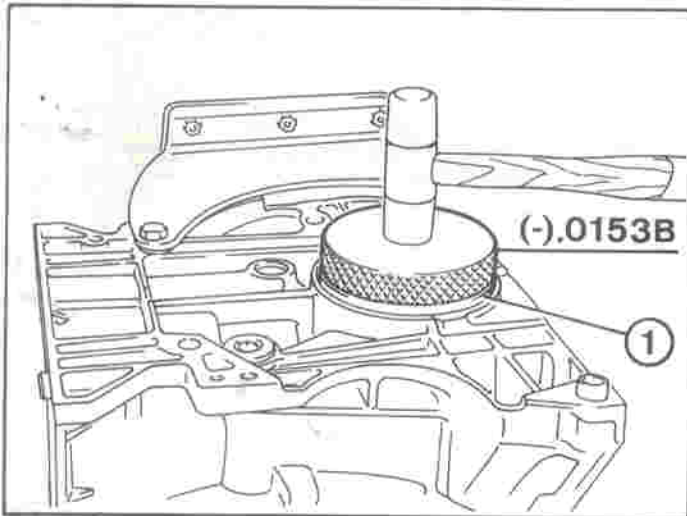

IV

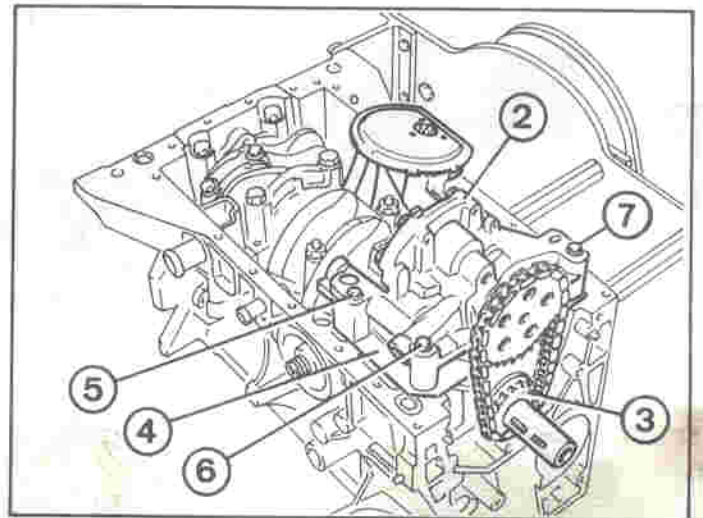

XU9J4

I

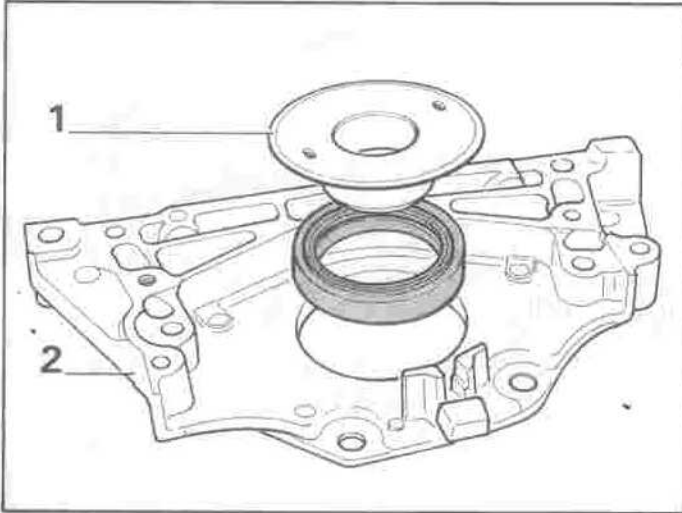

9-5-88 C84

II

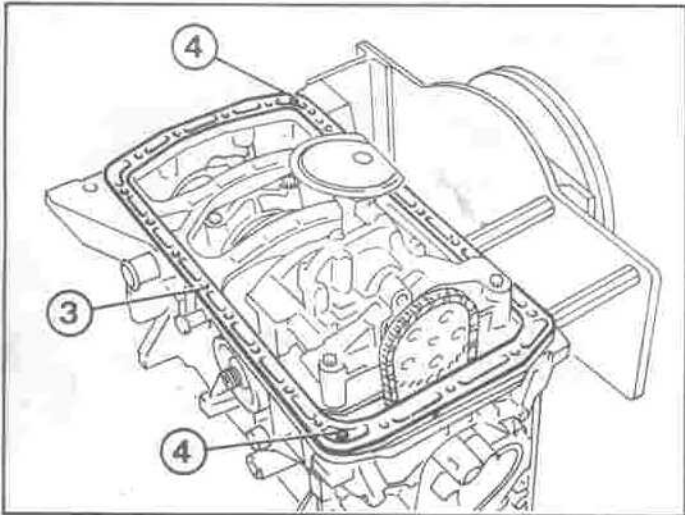

3-12-86 C40

III

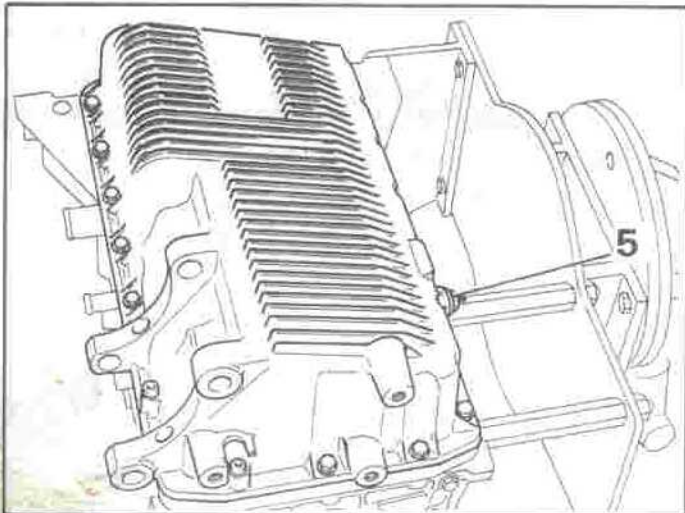

9-5-88 C52

IV

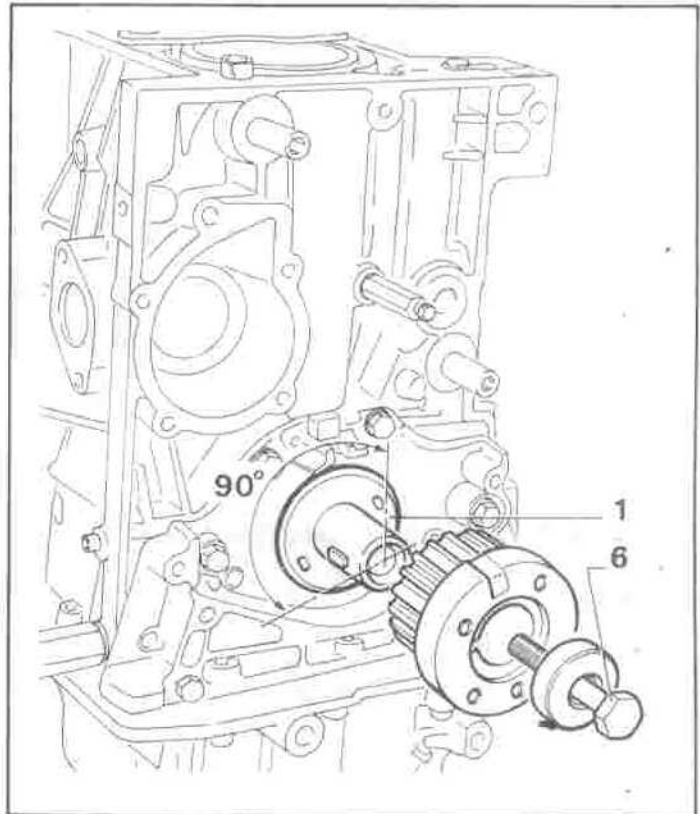

9-5-88 C80

V

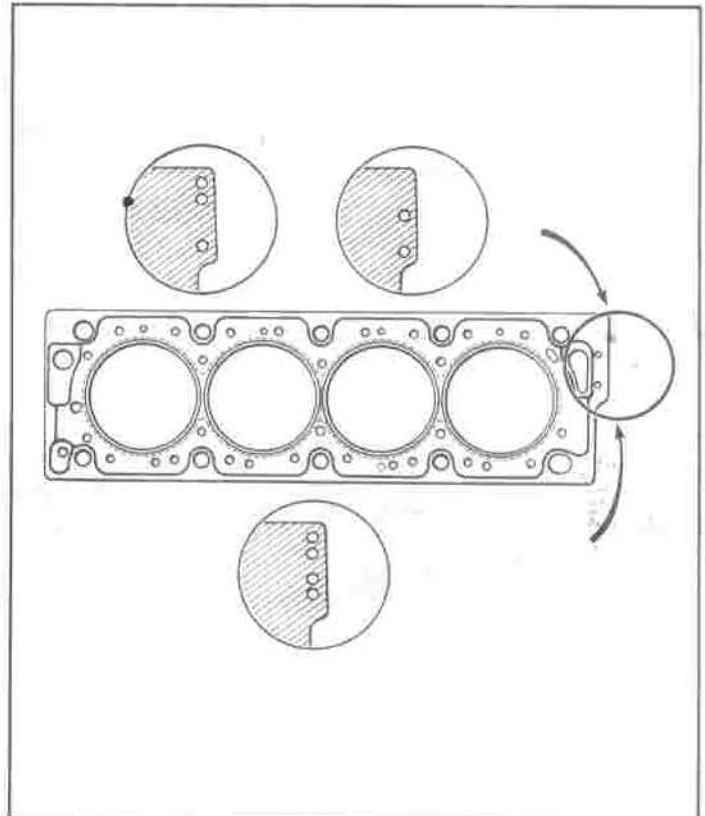

I

- Fit the new oil seal using the oil pump sprocket spacer (1)
- Coat the plate (2) with SILICONE CLASS 1 jointing paste
- Tighten the bolts to 15 Nm (11 lbf ft)

II

- Coat the face of the spacer (3) in contact with the cylinder block with SILICONE CLASS 1 jointing paste
- Fit the spacer (3)
- Tighten the two bolts (4) to 10 Nm (7 lbf ft)

III

- Fit the sump using SILICONE CLASS 1 jointing paste

NOTE

Depending on specification, some engines are fitted with two short bolts at no. 1 main bearing end.

- Tighten the bolts to 20 Nm (15 lbf ft)
- Fit the oil temperature sensor (5)

IV

- Turn the crankshaft to position the key at approximately 9 o'clock
- Fit the flywheel, coating the bolts with THREADLOCK LOCTITE
- Fit the flywheel locking tool of FACOM D86 type
- Tighten the bolts 50 Nm (37 lbf ft)
- Fit the clutch unit using mandrel (-).0213
- Tighten the bolts to 25 Nm (18 lbf ft)
- Fit :
 - the spacer (1)
 - the timing gear and its key
- Tighten the bolt (6) to 110 Nm (81 lbf ft)
- Remove the flywheel locking tool

V

CYLINDER HEAD

- Remove the clamps (-).0132 A12
- Check that the head face is clean
- Position a new cylinder head gasket, dry

IMPORTANT

For head gasket identification, see identification page

I

- Position the cylinder head
- Coat the threads and underside of the head of the bolts with MOLYKOTE G RAPID PLUS
- Fit the spacers under the bolt heads
- Fit and tighten the bolts in two stages, bolt by bolt, in the order shown opposite :
 1. Pre-tightening to 60 Nm (44 lbf ft)
 2. Slacken, then tighten to 20 Nm (15 lbf ft) followed by a further 300° tightening using a tool of FACOM D360 type

II

COOLANT PUMP

- Fit the coolant pump (1), using a new joint
- Tighten to 15 Nm (11 lbf ft)
- Fit the cover (2) with the slot (3) over the flange (4)
- Tighten the bolts 10 Nm (7 lbf ft)
- Fit the tensioning rollers to their pins without tightening the bolts

III

TIMING GEARS

- Fit the camshaft gears (5) and (6) with their keys
- Lock the bolts (7) with washers at 45 Nm (33 lbf ft)

NOTE

For tightening, lock the camshafts with an open-ended spanner

IV

- Position :
 - the camshafts, using rods (-).0153 M
 - the crankshaft, using rod (-).0153 G
- Fit the timing belt in its direction of running (arrows) in the following order :
 - camshaft gears (5) and (6)
 - tension roller (7)
 - crankshaft gear (8)
 - coolant pump gear (1)
 - tension roller (9)

V

- Attach the belt tension measuring equipment to the belt (a) and lock it
- Rotate the tension roller (7) one complete turn
- Turn the tension roller (7) anticlockwise to obtain a reading of 19 SEEM units (6 daN/run)
- Tighten the bolt (10) to 20 Nm (15 lbf ft)

I

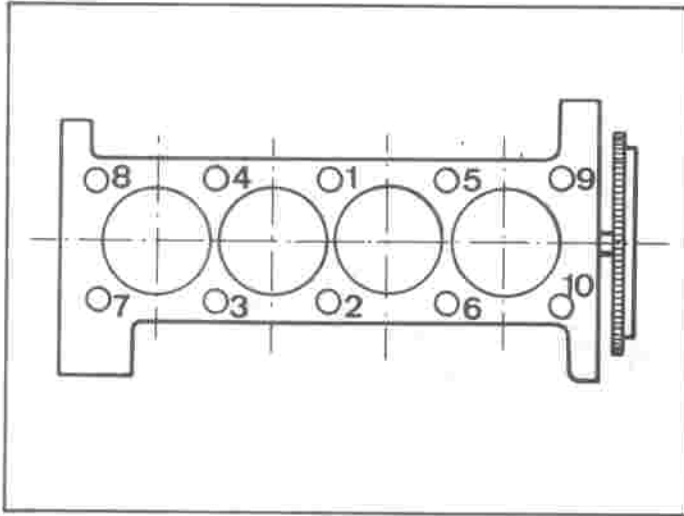

II

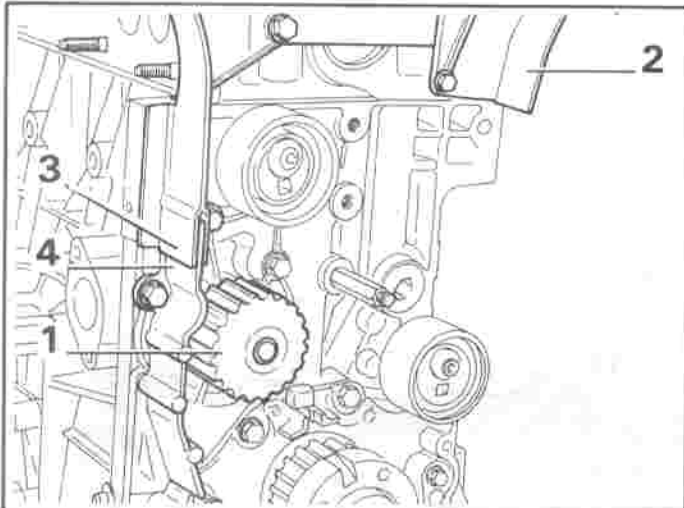

9-5-88 C78

III

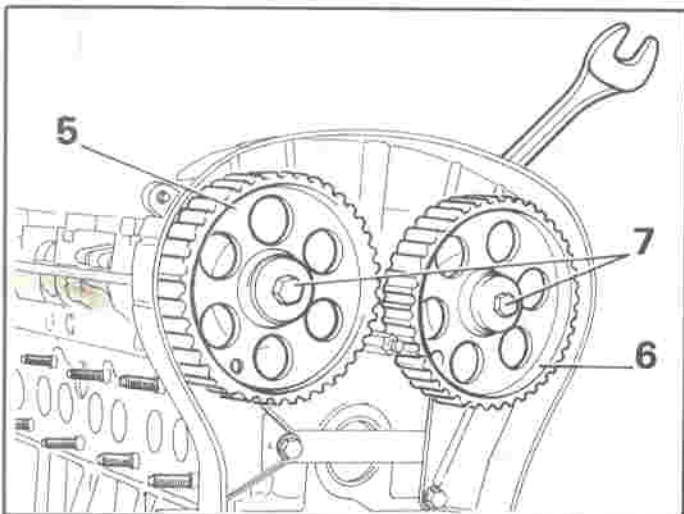

9-5-88 C75

IV

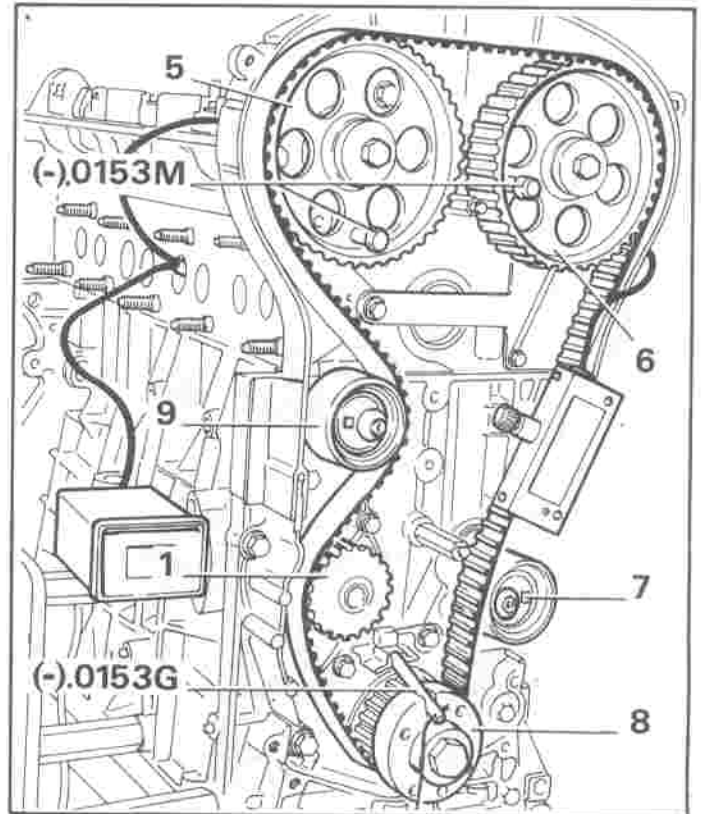

9-5-88 C59

V

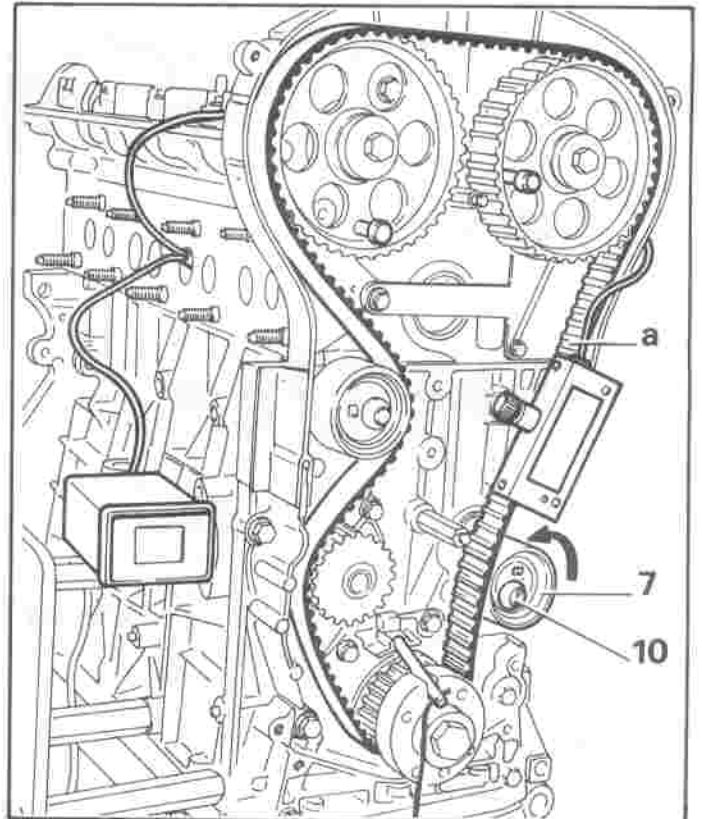

9-5-88 C57

XU9J4

I

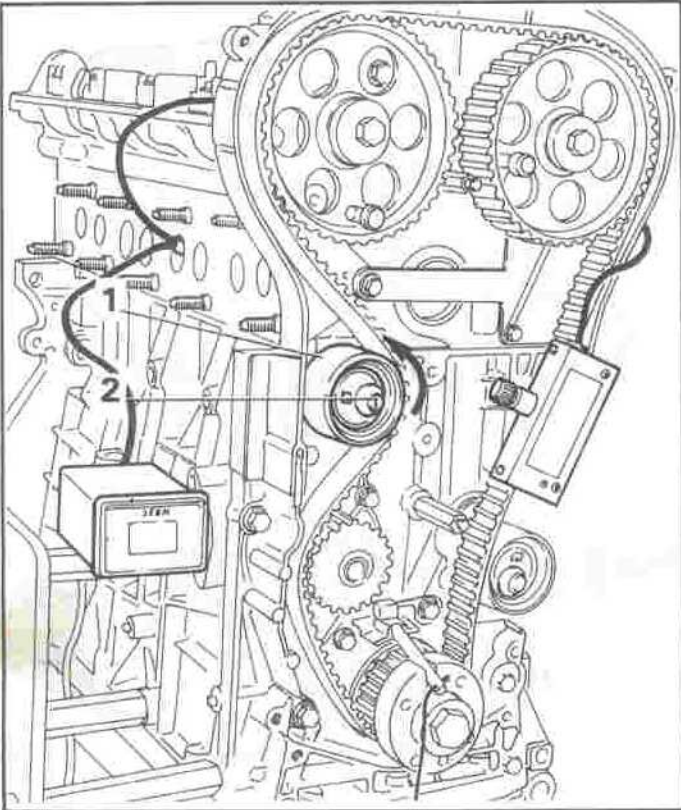

9-5-88 C55

III

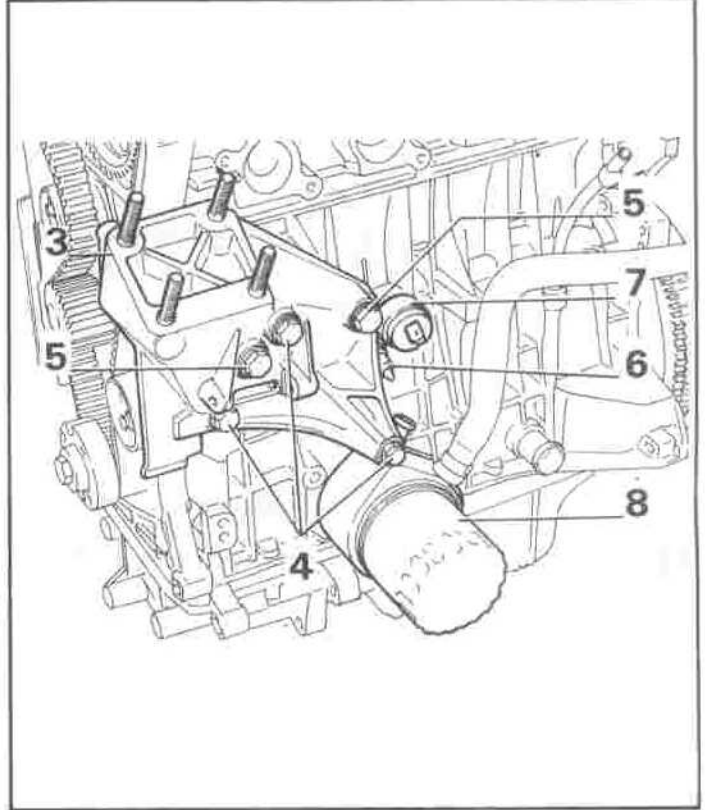

9-5-88 C95

II

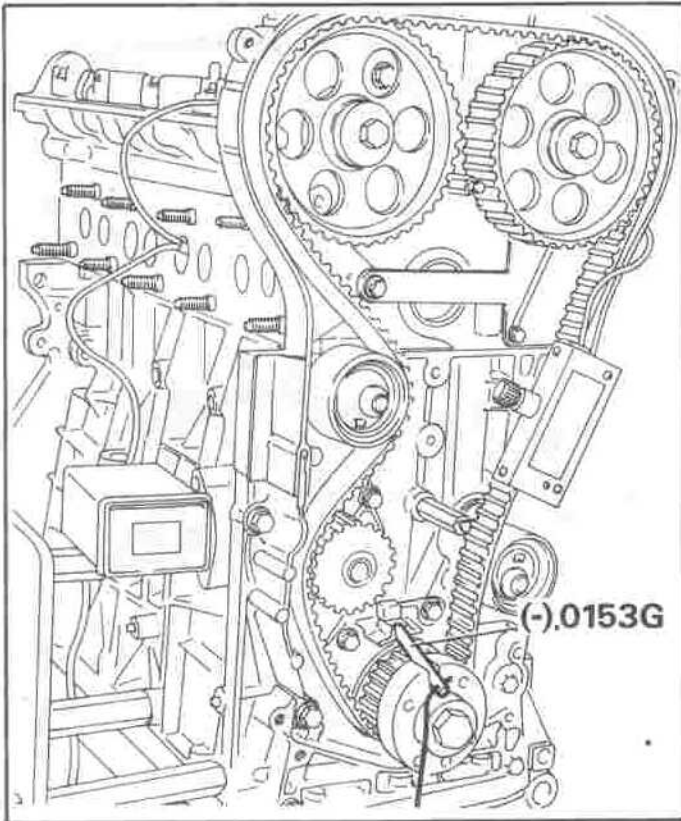

9-5-88 C55

IV

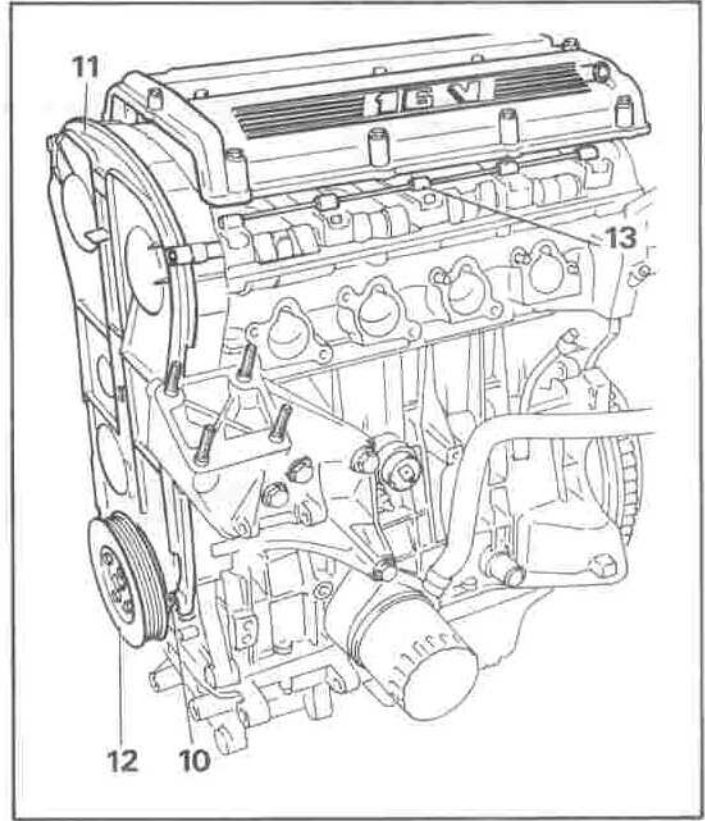

9-5-88 C87

I

- Turn the tension roller (1) anticlockwise to obtain a reading of 21 SEEM units (8 daN/run) on the display
- Tighten the bolt (2) to 20 Nm (15 lbf ft) without moving the position of the tension roller
- Remove the three rods
- Turn the crankshaft two revolutions in the running direction

III

- Coat the bolts with THREADLOCK LOCTITE and fit the engine mounting (3)

NOTE

Ensure the centralising dowel is fitted to the cylinder block

- Tighten :
 - the bolts (4) to 45 Nm (33 lbf ft)
 - the bolts (5) to 72 Nm (53 lbf ft)
- Fit :
 - the oil pressure switch (6)
 - the oil pressure sensor (7)
 - the cooler (8), with the bolts coated with THREADLOCK LOCTITE
 - the oil filter

II

- Position the crankshaft using rod (-).0153 G

IMPORTANT

It must be possible to insert the camshaft gear rods easily. If not, repeat the operation

- Attach the equipment to the belt
- A reading of between 40 and 50 SEEM units (20 to 30 daN/run) should be obtained
- If the reading is outside this tolerance repeat the belt tensioning operation
- Remove the setting rod

IV

- Fit covers (10) and (11) in that order
- Tighten the bolts to 10 Nm (7 lbf ft)
- Fit the crankshaft pulley (12) and tighten to 25 Nm (18 lbf ft)
- Fit :
 - the lubrication pipe (13)
 - the spark plugs
 - the cylinder head cover and tighten the bolts to 10 Nm (7 lbf ft)

I

- Fit :
 - the sealing plate (1)
 - the rotor support (2)
- Coat the bolts (3) with THREAD-LOCK LOCTITE and tighten them to 40 Nm (30 lbf ft)
- Fit :
 - the rotor (4) and tighten the bolts to 3 Nm (2 lbf ft) (nominal)
 - the distributor cap (5)

IV

- Fit the alternator and its belt

NOTE

- Belt tension
 - new : 80 SEEM units (75 daN/run)
 - used : 60 to 63 SEEM units (40 to 45 daN/run)

II

- Coat the thermostat housing (6) with sealing compound (SILICONE CLASS 1)
- Fit :
 - the thermostat housing and tighten to 10 Nm (7 lbf ft)
 - the thermostat, the joints and the housing cover
- Fit :
 - the plug leads
 - the plate (7)
 - the half cover (8)
 - the pulley (9)
- Tighten the bolt (10) to 45 Nm (33 lbf ft)

V

- Fit :
 - the oil level sensor (12)
- the exhaust manifold fitted with new gaskets
- Tighten the nuts (13) to 10 Nm (7 lbf ft)
- Fit the coolant inlet union (14) using a new joint

III

- Fit the inlet manifold (11) with its gaskets and tighten to 20 Nm (15 lbf ft)

I

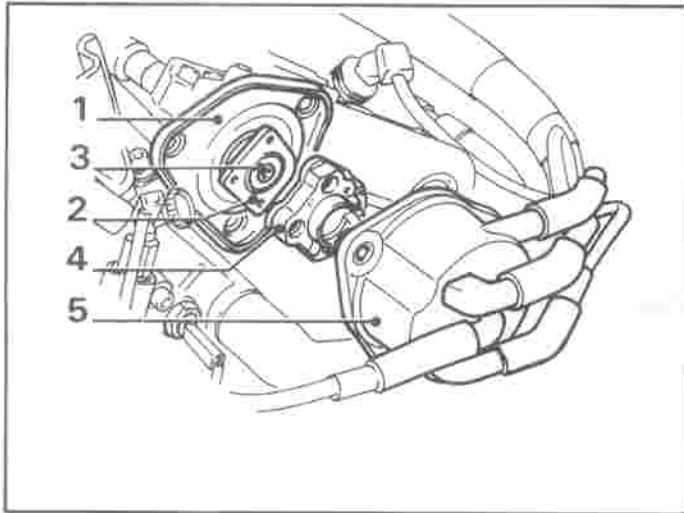

IV

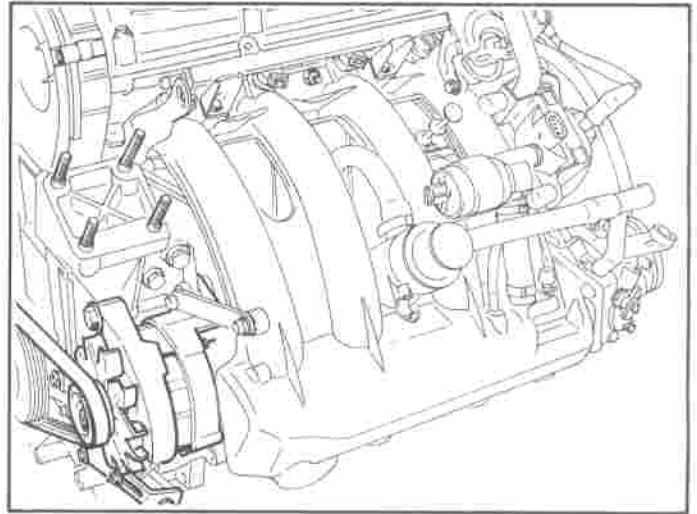

II

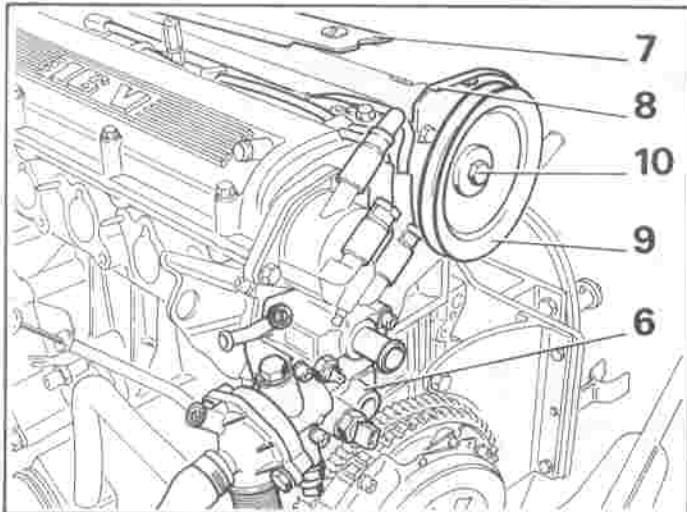

9-5-88 C97

V

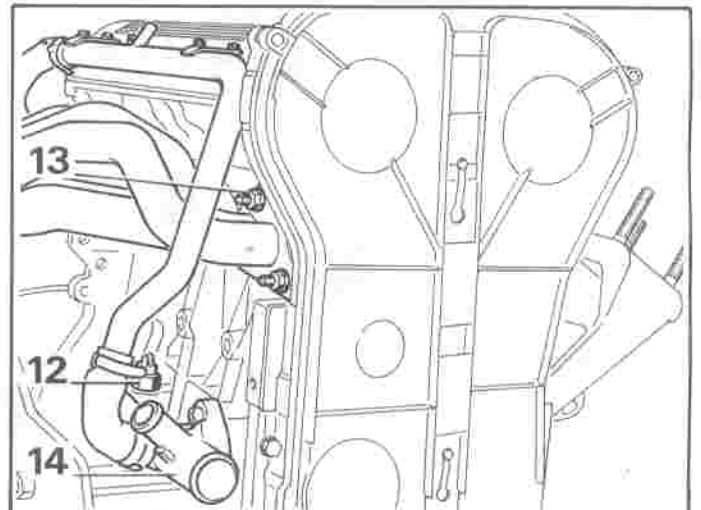

9-5-88 C89

III

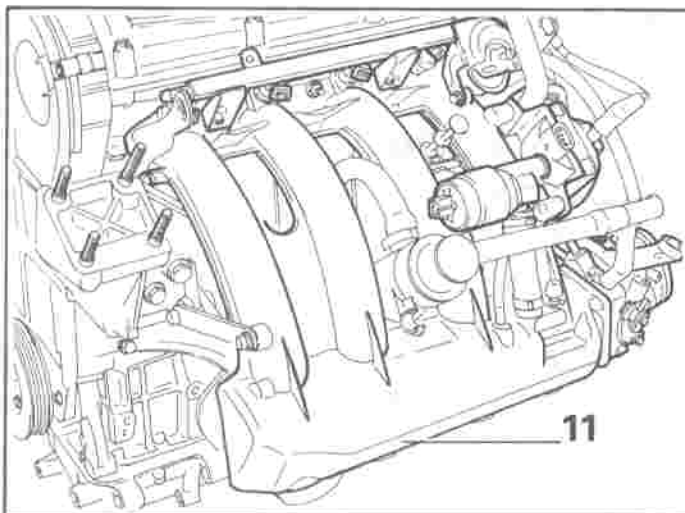

9-5-88 C94

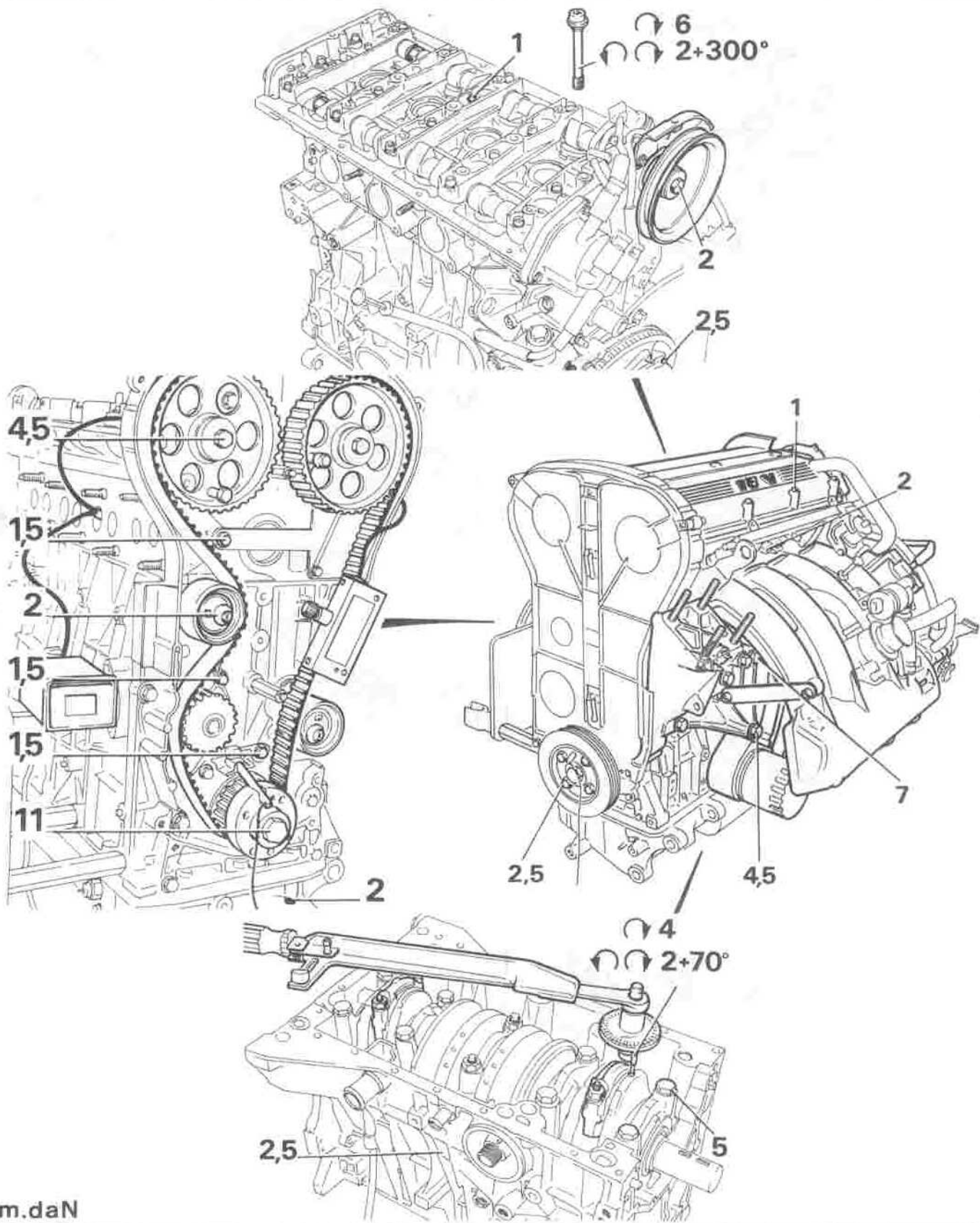

m.daN

PRINCIPAL TIGHTENING TORQUES

XU9J4

The tightening torques shown opposite are expressed in m.daN. The equivalent values are :

m.daN	lbf ft
1	7
1,5	11
2	15
2,5	18
4	30
4,5	33
6	44
7	52
11	81